

All dimensions are shown in inches unless otherwise stated.

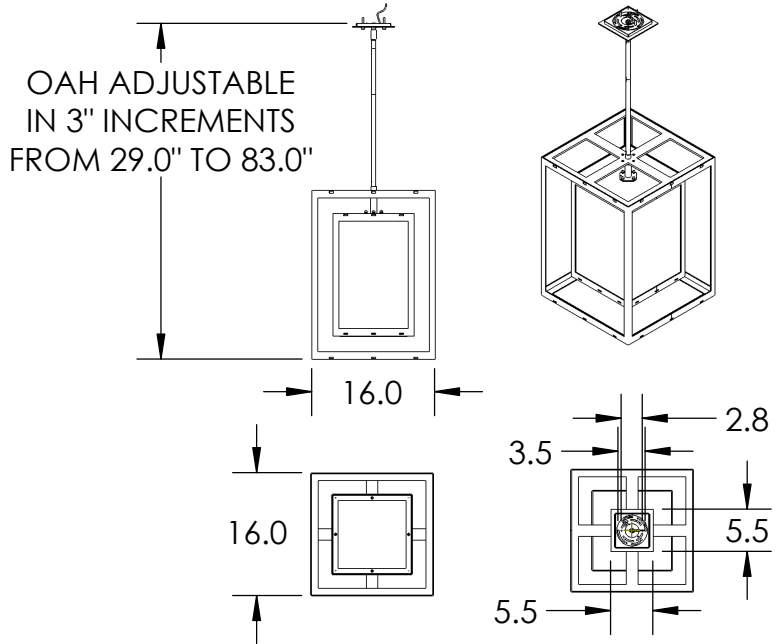

Mounting Method: J-Box Ceiling Mount

PRODUCT DESCRIPTION

This versatile contemporary pendant features a nested box design with an open outer frame and a frosted glass inner lens.

The Double Box pendant is offered in three AAMA 2604-rated finishes that withstand UV and corrosion resistance in coastal and other harsh climates, and it includes a lifetime warranty to the original purchaser.

SCAN FOR MORE INFORMATION

PRODUCT SPECIFICATION

Bulbs Not Included

Construction: Aluminum Body With Glass Panes

Finish Options: **AG** **SB** **TB**

Glass Types: **F**

Suspension Method: Ceiling Mount

Weight(lbs.): 24

UL Rating: Damp

Top Diffuser: Closed Metal

Bottom Diffuser: Closed Glass

Light Source: Incandescent

Bulb Qty: 4

Wattage (Watts):60

Voltage (Volts):120

Bulb Type: A

Socket Type: Medium, E26

Driver Quantity & Location:0

Notes:

GENERAL NOTES:

Visit studio.hammerton.com to read about our Lifetime Limited Warranty.

All Hammerton fixtures are handcrafted by artisans. Subtle imperfections reflect the mark of the artisan and should be expected in any handcrafted product. Dimensions may vary up to 7/8".

Rev 10/22/2024