

## Included Components

- Hardware Packet X, with Instructions
- Glass Panels (QTY:20)
- Canopy
- Coax Conductive Cable (QTY:10)
- Coax Conductive Cable, Practice Section (QTY:1)
- Light Body (QTY:10)
- Cylinder Knobs with All Thread (QTY:80)
- Silicon washers (QTY:160)

## Required Tools

- Philips screw driver (not provided)
- Wire strippers (not provided)
- Cable Cutters (not provided)
- Measuring tape (not provided)

# STOP!

Please read these instructions carefully and watch the instruction video before you start. Use the link or QR code in the bottom right hand side of these instructions.

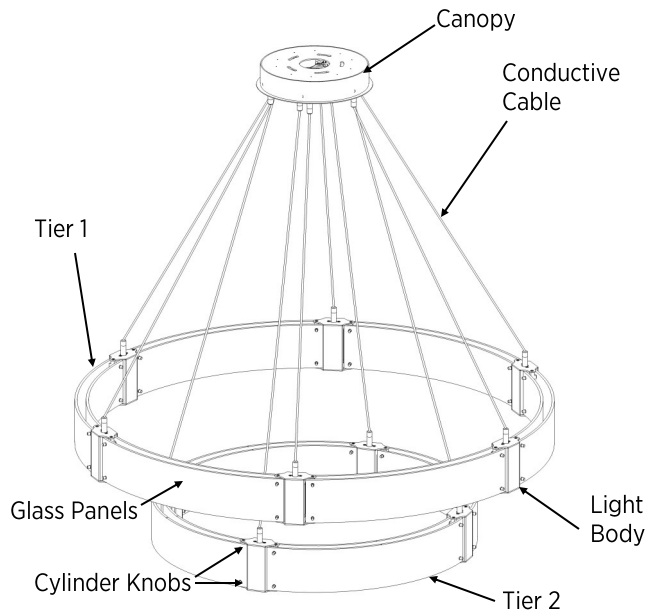

## Assembly Instructions

**Step 1:** Cut conductive cables for both tiers to desired length using **cable cutters, not wire cutters or diagonal cutters**. Failure to use cable cutters will result in the inner conductive cable not being cut cleanly. Note the cable will be inserted into the grippers. See OAH Chart for reference while determining the cut length.

**Step 2:** Connect conductive cable's to the canopy. Tier 2 connects to the four inner canopy connections and Tier 1 to the six outer canopy connections. **Use the included practice section of the coax conductive cable until you feel confident installing the cable.**

- Mark the conductive cable 1-1/8" from both ends.
- Unscrew the Cap from the cable gripper and slide it over the conductive cable.
- Cut the outer sheathing and insulator with a **16 Ga. Wire stripper**. Open the stripper, rotate 90° and repeat until sheathing is completely cut.
- Strip the wire by wrapping the cable around your hand and using a **14 Ga. Wire Stripper**.
- Flare out the outer braided sheathing so that it will lay on the outside of the nipple on the cable gripper
- Insert the cable into the gripper until it bottoms out. The insulator will go into the gripper while the outer sheathing will lay over the outside of it.
- Secure the cap back onto the gripper. **Be careful when tightening the cap not to cut the outer sheathing.**
- Smooth out sheathing by pinching the cable and pulling away from the gripper.

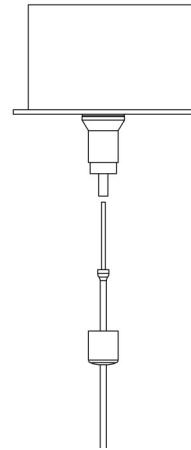
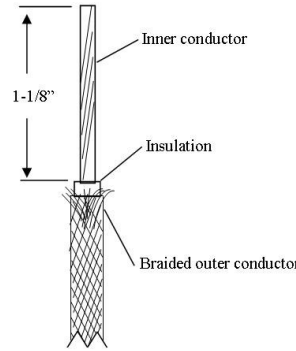

**Step 3:** Mount Canopy to the J-Box by first removing the Cover Plate, unscrew the flat head screws (QTY:2). Secure canopy to building structure. See included mounting instructions. Make wire connections to source power and replace cover plate.

**Step 4:** Verify cables are all the right height. Then repeat step 2 to mount the light body's to the conductive cable. **Light bodies of each tier should hang at the same height, adjust if needed.**

**Step 5:** Install glass panels onto light bodies of Tier 1.

- Place one silicon washer on each cylinder knob with all thread
- Attach the all thread to the glass panels, by inserting them through the holes in the glass and inserting a second silicon washer onto the all thread . **NOTE: Cylinder knob must be the outside surface of the glass. (Smooth on granite. Textured on Rimelight)**
- Install glass onto light bodies. Align all thread with

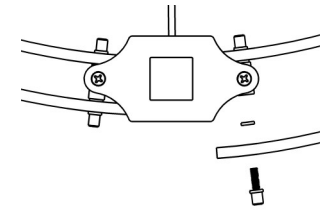

**Note:** The phillips head screws shown in the above image are used to tighten/loosen the glass mounting brackets.

Repeat Step 5 for Tier 2

## Overall Height Chart

Use this chart as a reference to determine the cut length of the conductive cable. Lengths are in inches. Refer to Spec Sheet for minimum OAH

Tier 1		Tier 2	
OAH	Cable	OAH	Cable
30	30 2/16	40	34 14/16
40	38 1/16	50	44 7/16
50	46 13/16	60	54 2/16
70	65 8/16	80	73 13/16
90	84 13/16	100	93 9/16
105	99 7/16	115	108 8/16
115	109 5/16	125	118 7/16

## Troubleshooting Guide

- If one of the light bodies does not light up, disconnect power to fixture immediately and rewatch video.
- If glass is sagging, ensure that there are silicon bushings installed in the glass.

**Installation Help:** Please scan the QR code or follow the URL to see our installation help page. This page includes a video walkthrough of how to wire the conductive cable.



<http://hammertonstudio.com/installation-help>

## About Hammerton Studio

### HAMMERTON STUDIO

When we introduced the Hammerton Studio brand in 2014, we saw an enormous opportunity to raise the bar in decorative lighting. In design, we wanted to lead rather than follow. In construction, we wanted to showcase Hammerton's renowned reverence for time-honored artisan craftsmanship and authentic materials. In performance, we wanted to provide highly reliable solutions that far exceeded industry norms for aesthetics, function, and quality. Based on the brand's dramatic growth and customer feedback, it's clear we are on the right track.

### EXTRAORDINARY DESIGN VALUE IN ARTISAN GLASS & METALWORK

Hammerton began in 1995 as a blacksmith shop, but we've come a long way since then. Today we employ a world class team of metal artisans who are disciplined in a broad range of fabrication techniques and processes. We've also added in-house capabilities in blown, cast and kiln-fused glass, and today Hammerton operates one of the largest artisan glass production facilities in the U.S. With deep design and fabrication expertise at the intersection of glass and metalwork, we're laying the foundation for a new era of lighting innovation.

### THE HAMMERTON HERITAGE

Our Hammerton Studio brand stands on the shoulders of more than a quarter century of experience pushing the boundaries of innovative custom lighting design. Each Hammerton Studio collection has been inspired by custom work our company has brought to life in collaboration with leading interior design professionals over the years. Built to your specifications, every fixture reflects the uncompromising design and attention to detail that is distinctly Hammerton.

### A REPUTATION REFLECTED BY OUR CLIENTS

Hammerton fixtures are as extraordinary as the clients who purchase them, including Forbes 400 members, Fortune 500 leaders, award-winning entertainers, fashion and interior designers, sports legends, and leading luxury hospitality brands.

Hammerton Inc.  
217 Wright Brothers Drive  
Salt Lake City, UT 84116

801-973-8095 EXT: 4  
[www.hammerton.com](http://www.hammerton.com)

## Warranty

### ONE YEAR LIMITED WARRANTY

Hammerton, Inc. (Hammerton) warrants the original owner that this product will be free of defects in material or workmanship for the period of one year from the date of original purchase from Hammerton, if (i) the allegedly defective product has not been abused, misused or improperly maintained and or repaired during the warranty period, (ii) the defect is not caused by water damage/flooding, fire, explosion, earthquakes or similar phenomenon, and (iii) the defect is not caused by improper installation (unless installed by Hammerton).

In order to obtain warranty service, the user must first complete a warranty claims form. Hammerton will determine if the product will be inspected on site or returned to Hammerton. If after the inspection Hammerton finds that the product is defective as claimed, Hammerton will, at its option, repair or replace the product free of charge, or Hammerton may also agree to outsource necessary repair work locally using local contracted labor. Prior to any outsourcing of repair work regarding this fixture, a Work Authorization Form must be signed by both the client and Hammerton Representative. Failure to do so may result in a denial of reimbursement. Hammerton warrants any replaced or repaired products for ninety days after shipment or through the end of the original warranty period, whichever is longer. All products or parts that are replaced become the property of Hammerton.

No representative or employee of Hammerton is authorized to make any modification or addition to this limited warranty.

TO THE FULL EXTENT ALLOWED BY LAW, THE FOREGOING WARRANTY AND REMEDIES ARE EXCLUSIVE, AND HAMMERTON EXPRESSLY DISCLAIMS ALL OTHER WARRANTIES, EXPRESSED OR IMPLIED, INCLUDING WITHOUT LIMITATION THE IMPLIED WARRANTIES OF MERCHANTABILITY AND FITNESS FOR A PARTICULAR PURPOSE. TO THE FULL EXTENT ALLOWED BY LAW, HAMMERTON EXCLUDES AND DISCLAIMS LIABILITY, WHETHER BASED IN CONTRACT OR TORT (INCLUDING NEGLIGENCE FOR ANY CONSEQUENTIAL, INDIRECT INCIDENTAL OR SPECIAL DAMAGES OF ANY NATURE ARISING OUT OF THE SALE INSTALLATION, MAINTENANCE, USE OR FAILURE OF THIS PRODUCT, EVEN IF HAMMERTON HAS BEEN ADVISED OF THE POSSIBILITY OF SUCH DAMAGES IN ADVANCE, AND HAMMERTON LIMITS ITS LIABILITY TO REPLACEMENT, REPAIR OR REFUND OF THE PURCHASE PRICE PAID, AT HAMMERTON'S OPTION.)

SOME STATES DO NOT ALLOW LIMITATIONS ON HOW LONG AN IMPLIED WARRANTY LASTS AND/OR DO NOT ALLOW THE EXCLUSION OR LIMITATION OF INCIDENTAL OR CONSEQUENTIAL DAMAGES, SO THE ABOVE LIMITATION ON IMPLIED WARRANTY AND INCIDENTAL OR CONSEQUENTIAL DAMAGES MAY NOT APPLY TO YOU. THIS WARRANTY GIVES YOU SPECIFIC LEGAL RIGHTS YOU MAY HAVE OTHER RIGHTS, WHICH VARY FROM STATE TO STATE

# HAMMERTONSTUDIO™

## Assembly Instructions LED, Parallel Glass Chandeliers

CHB0042-2B

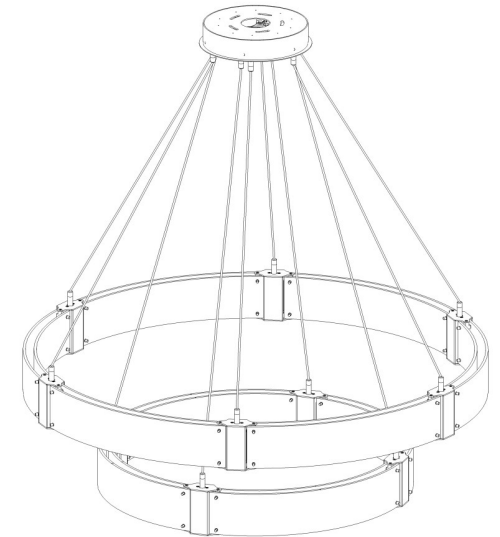

## STOP!

Please read these instructions carefully and watch the instruction video before you start. Use the link or QR code found in these instructions to navigate to the video.

**WARNING: FAILURE TO INSTALL THIS  
FIXTURE PROPERLY MAY RESULT IN  
SERIOUS PERSONAL INJURY OR DEATH  
AND PROPERTY DAMAGE.**

It is recommended that this product be installed  
by a licensed electrician.

41-001-00023  
Rev 3