

Included Components

- A. Hardware Packet X with Instructions
- B. Fixture Body
- C. Cast Glass with Silicon Washer and Glass Bracket
- D. Canopy
- E. Suspension Rod Set

Required Tools

- 1. 9/64" Allen Key (provided)
- 2. Slotted Drive Screw Driver (not provided)
- 3. Wire Cutters/Strippers (not provided)
- 4. Measuring Tape (not provided)

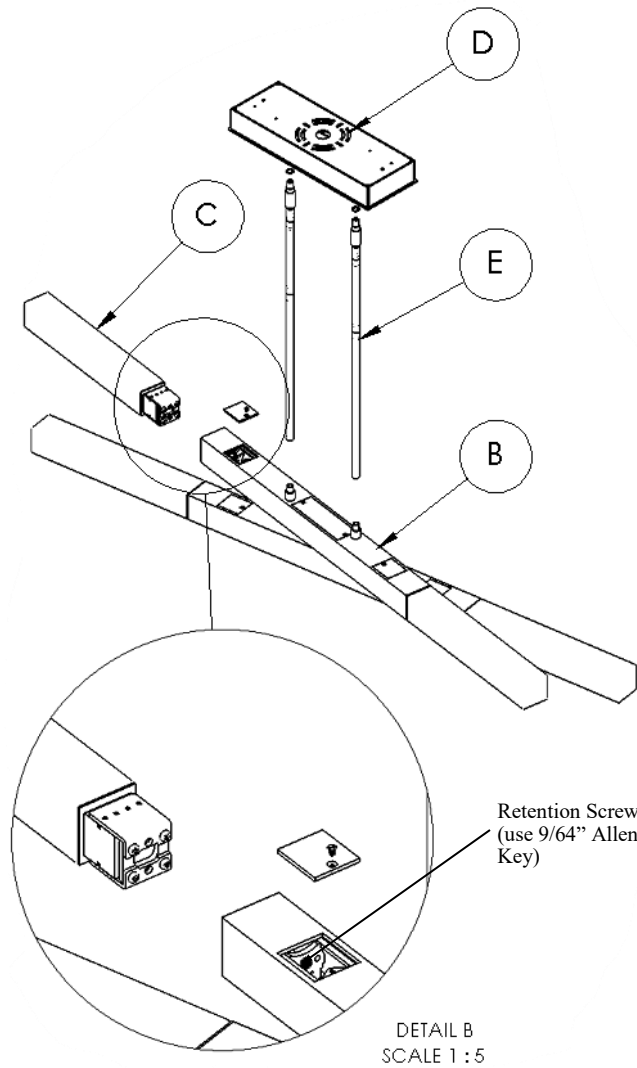

Fixture Glass Install Instructions

- Step 1:** Install Aluminum Glass Bracket as shown above with Silicon washer properly seated.
- Step 2:** Remove small access panel on fixture body using slotted drive screw driver. This will expose the glass retention screw.
- Step 3:** Orient glass as shown, so aluminum faces of glass bracket are facing up and down. Threaded hole on glass bracket will be aligned with retention screw when properly oriented.
- Step 4:** Insert Glass assembly into end of Fixture Body Tube. Look through Access panel to align retention screw and thread into hole on glass bracket.
- Step 5:** Tighten retention screw with provided 9/64" Allen key so glass is secure and hanging straight.

Note: Take care not to over-tighten screw

Fixture Hanging and Assembly Instructions

Step 1: Test Fit Threaded Rods with Light Fixture and Canopy to determine Threaded Rod configuration to reach desired overall height. The wire will need to pass through the rods into the canopy.

Note: The two shorter IPs (7/8") are used with the 90 degree swivel and 1" Straight Coupler.
NOT BETWEEN THREADED RODS.

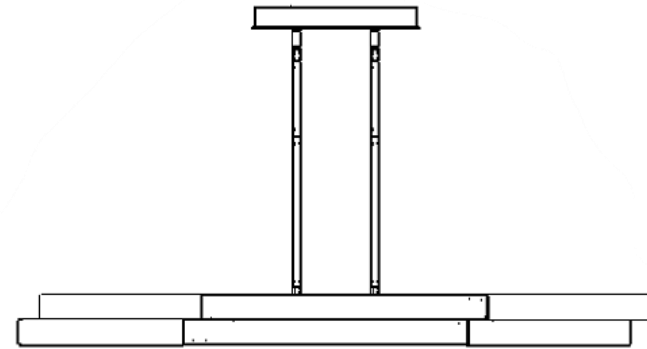

Step 2: Apply Loctite to the Male threads of the 90 degree swivel and thread that into the 1" Straight Coupler until bottomed out. Then apply Loctite to both 7/8" long IPs and thread them into both the 90 Degree Swivel and the Straight coupler until the IPs Bottom out.

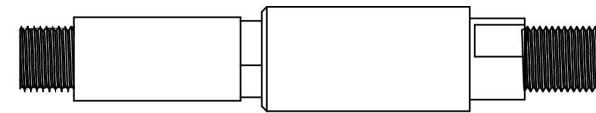

Step 3: Apply Loctite to the IP inserted into the 90 Degree Swivel. Screw the top rod onto the IP until it bottoms out against the 90 Degree Swivel.

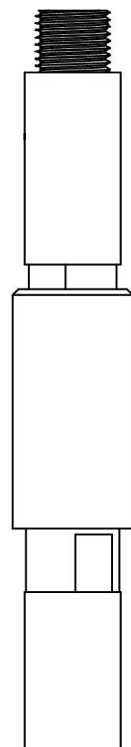

Step 4: Apply Loctite to one side of each IP used with the Threaded Rods. Screw them into the rod until it bottoms out. Then apply Loctite to the other side and screw the second rod on until it bottoms out with the other rod.

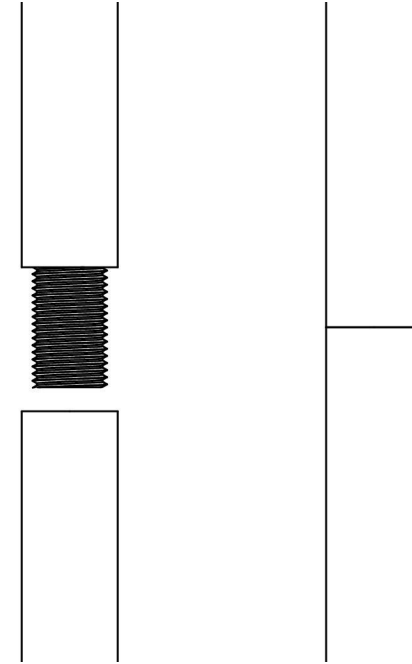

Step 5: Before applying the Loctite on the last IP push the Wires from the Fixture through the whole Threaded Rod Assembly. Then apply Loctite to the last IP and screw it into the Coupler attached to the Light Fixture.

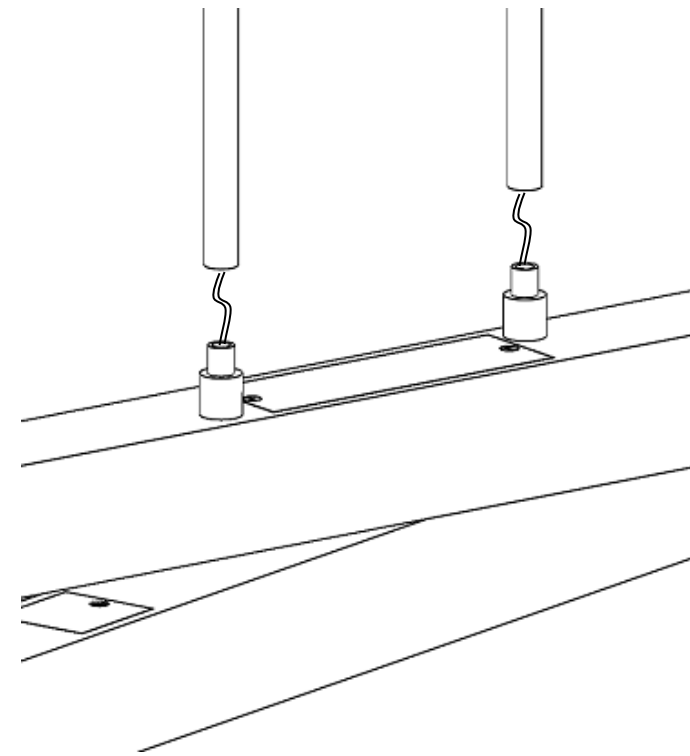

Step 6: Mount the canopy back plate to the ceiling and J-box following the included Mounting Instructions.

Step 7: Rotate the 90 Degree Swivels using the Flats by the Threaded Rods. The 90 degree Swivels should be lined up so that the light can be mounted on a ceiling that slopes perpendicular to the length of the light fixture.

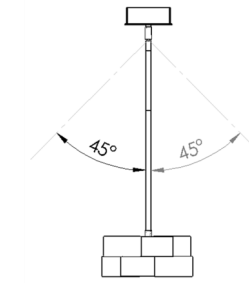

THE GLASS SHOULD NOT BE INSTALLED UNTIL AFTER THE FIXTURE IS FULLY INSTALLED.
Your fixture can be mounted on a sloped ceiling but only in the direction perpendicular to the long direction of the light bar. Slope mount only up to 45°.

Step 8: Remove Canopy Faceplates. Attach Swivel side of Rod and Fixture Assembly to Canopy using Lock Washers and IP Nuts. Tighten IP nuts with

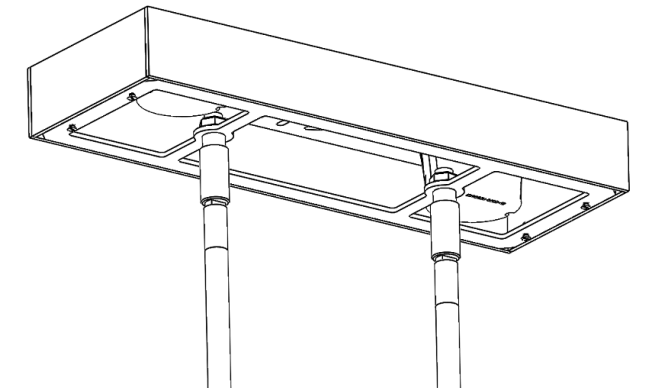

Step 9: Connect the wiring from the fixture to the junction box trimming back any unneeded wiring. Attach Wire Access Cover using cylinder knobs.

Step 10: Attach Canopy Face Plates to Canopy Body using the small flat head screws.

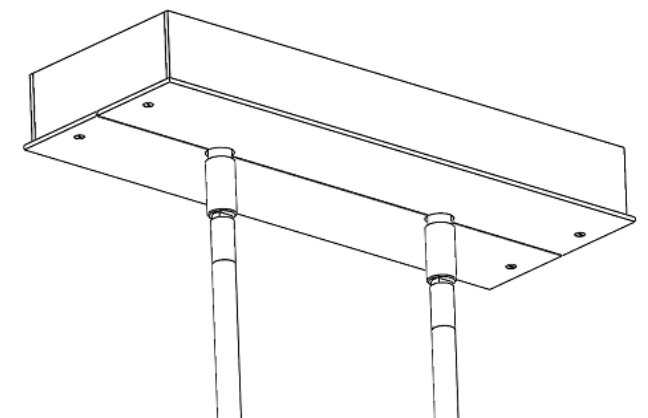

HAMMERTON STUDIO

When we introduced the Hammerton Studio brand in 2014, we saw an enormous opportunity to raise the bar in decorative lighting. In design, we wanted to lead rather than follow. In construction, we wanted to showcase Hammerton's renowned reverence for time-honored artisan craftsmanship and authentic materials. In performance, we wanted to provide highly reliable solutions that far exceeded industry norms for aesthetics, function, and quality. Based on the brand's dramatic growth and customer feedback, it's clear we are on the right track.

EXTRAORDINARY DESIGN VALUE IN ARTISAN GLASS & METALWORK

Hammerton began in 1995 as a blacksmith shop, but we've come a long way since then. Today we employ a world class team of metal artisans who are disciplined in a broad range of fabrication techniques and processes. We've also added in-house capabilities in blown, cast and kiln-fused glass, and today Hammerton operates one of the largest artisan glass production facilities in the U.S. With deep design and fabrication expertise at the intersection of glass and metalwork, we're laying the foundation for a new era of lighting innovation.

THE HAMMERTON HERITAGE

Our Hammerton Studio brand stands on the shoulders of more than a quarter century of experience pushing the boundaries of innovative custom lighting design. Each Hammerton Studio collection has been inspired by custom work our company has brought to life in collaboration with leading interior design professionals over the years. Built to your specifications, every fixture reflects the uncompromising design and attention to detail that is distinctly Hammerton.

A REPUTATION REFLECTED BY OUR CLIENTS

Hammerton fixtures are as extraordinary as the clients who purchase them, including Forbes 400 members, Fortune 500 leaders, award-winning entertainers, fashion and interior designers, sports legends, and leading luxury hospitality brands.

Hammerton Inc.
217 Wright Brothers Drive
Salt Lake City, UT 84116

801-973-8095
info@hammerton.com
www.hammerton.com

ONE YEAR LIMITED WARRANTY

Hammerton, Inc. (Hammerton) warrants the original owner that this product will be free of defects in material or workmanship for the period of one year from the date of original purchase from Hammerton, if (i) the allegedly defective product has not been abused, misused or improperly maintained and or repaired during the warranty period, (ii) the defect is not caused by water damage/flooding, fire, explosion, earthquakes or similar phenomenon, and (iii) the defect is not caused by improper installation (unless installed by Hammerton).

In order to obtain warranty service, the user must first complete a warranty claims form. Hammerton will determine if the product will be inspected on site or returned to Hammerton. If after the inspection Hammerton finds that the product is defective as claimed, Hammerton will, at its option, repair or replace the product free of charge, or Hammerton may also agree to outsource necessary repair work locally using local contracted labor. Prior to any outsourcing of repair work regarding this fixture, a Work Authorization Form must be signed by both the client and Hammerton Representative. Failure to do so may result in a denial of reimbursement. Hammerton warrants any replaced or repaired products for ninety days after shipment or through the end of the original warranty period, whichever is longer. All products or parts that are replaced become the property of Hammerton.

No representative or employee of Hammerton is authorized to make any modification or addition to this limited warranty.

TO THE FULL EXTENT ALLOWED BY LAW, THE FOREGOING WARRANTY AND REMEDIES ARE EXCLUSIVE, AND HAMMERTON EXPRESSLY DISCLAIMS ALL OTHER WARRANTIES, EXPRESSED OR IMPLIED, INCLUDING WITHOUT LIMITATION THE IMPLIED WARRANTIES OF MERCHANTABILITY AND FITNESS FOR A PARTICULAR PURPOSE. TO THE FULL EXTENT ALLOWED BY LAW, HAMMERTON EXCLUDES AND DISCLAIMS LIABILITY, WHETHER BASED IN CONTRACT OR TORT (INCLUDING NEGLIGENCE FOR ANY CONSEQUENTIAL, INDIRECT INCIDENTAL OR SPECIAL DAMAGES OF ANY NATURE ARISING OUT OF THE SALE INSTALLATION, MAINTENANCE, USE OR FAILURE OF THIS PRODUCT, EVEN IF HAMMERTON HAS BEEN ADVISED OF THE POSSIBILITY OF SUCH DAMAGES IN ADVANCE, AND HAMMERTON LIMITS ITS LIABILITY TO REPLACEMENT, REPAIR OR REFUND OF THE PURCHASE PRICE PAID, AT HAMMERTON'S OPTION.)

SOME STATES DO NOT ALLOW LIMITATIONS ON HOW LONG AN IMPLIED WARRANTY LASTS AND/OR DO NOT ALLOW THE EXCLUSION OR LIMITATION OF INCIDENTAL OR CONSEQUENTIAL DAMAGES, SO THE ABOVE LIMITATION ON IMPLIED WARRANTY AND INCIDENTAL OR CONSEQUENTIAL DAMAGES MAY NOT APPLY TO YOU. THIS WARRANTY GIVES YOU SPECIFIC LEGAL RIGHTS YOU MAY HAVE OTHER RIGHTS, WHICH VARY FROM STATE TO STATE

Assembly Instructions

LED, Axis Glass Chandeliers

PLB0060-50

PLB0060-64

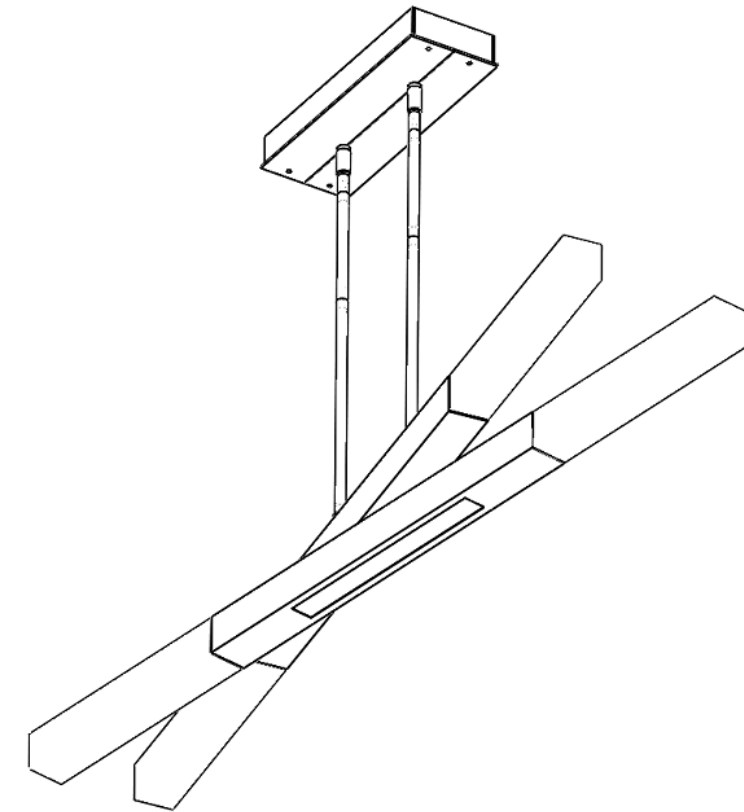

EXAMPLE: PLB0060-50

WARNING: FAILURE TO INSTALL THIS FIXTURE PROPERLY MAY RESULT IN SERIOUS PERSONAL INJURY OR DEATH AND PROPERTY DAMAGE.

WARNING: MUST USE MANUFACTURER SPECIFIED BULB. USING ANY OTHER TYPE OR WATTAGE BULB MAY CAUSE DAMAGE TO THE FIXTURE AND CREATE A POTENTIAL FIRE HAZARD.

It is recommended that this product be installed by a