

# HAMMERTONSTUDIO™

## Assembly Instructions SINGLE PENDANT

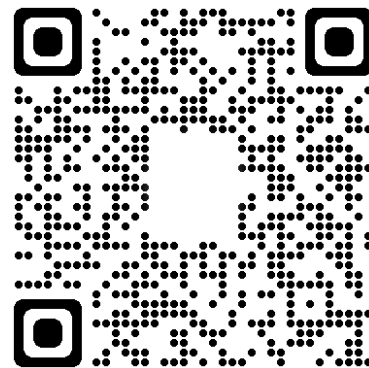

SCAN FOR VIDEO  
INSTRUCTIONS

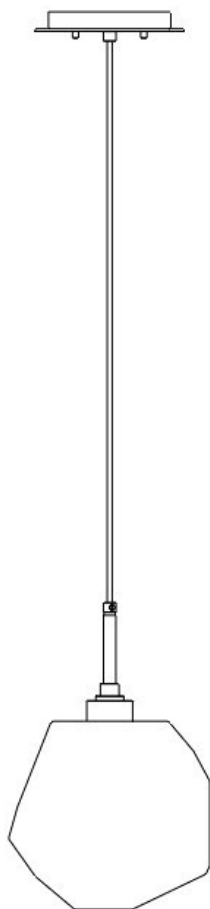

EXAMPLE

**WARNING: FAILURE TO INSTALL THIS FIXTURE PROPERLY MAY RESULT IN SERIOUS PERSONAL INJURY OR DEATH AND PROPERTY DAMAGE.**

It is recommended that this product be installed by a licensed electrician who is familiar with proper LED installation and electrical loads.

41-001-00190  
Rev 2

## Required Tools

1. Philips screw driver (not provided)
2. Wire cutters/strippers (not provided)
3. Measuring tape (not provided)
4. Flat blade screw driver (not provided)

## Included Components

- A. LED Driver
- B. Hardware Packet Y, with Instructions
- C. Canopy
- D. Cord grip (attached to canopy)
- E. Pendant assembly
- F. Blown Glass

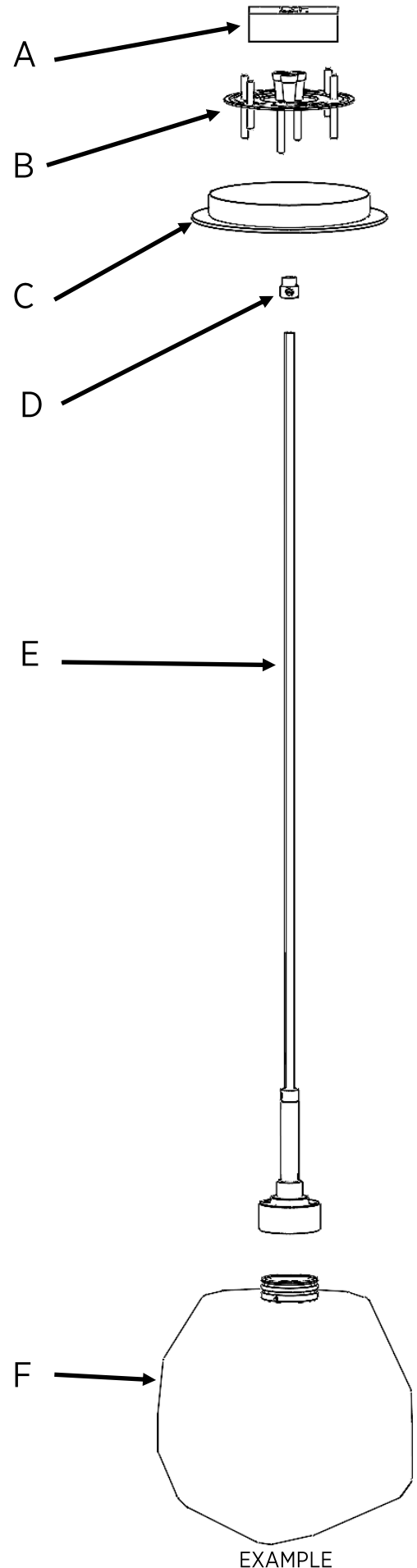

### **IMPORTANT**

DRIVER TO BE INSTALLED IN J-BOX.  
MINIMUM SIZE OF J-BOX REQUIRED IS  
4" L x 4" W x 1.5" H

EXAMPLE

# ASSEMBLY

## Step 1

**TURN OFF POWER TO JUNCTION BOX TO BE USED FOR INSTALLATION.**

## Step 2

Connect the **WHITE** wire from the LED Driver to the **WHITE** wire from the power source inside the J-Box using one of the provided Orange wire nuts. Follow the same steps for the two **BLACK** wires.

### WARNING

THE **BLUE** AND **RED** LEADS FROM THE DRIVER ARE FOR DC CURRENT ONLY. IF THESE LEADS OR THE LED PENDANTS ARE CONNECTED TO AC POWER THE FIXTURE WILL BE DAMAGED.

## Step 3

Mount the driver to the top of the universal plate provided in the mounting packet using the double sided tape pre-attached to the driver. Then affix the universal plate to the J-Box using the 1.5" L #8-32 screws provided in the mounting pack. The **Blue, Red, Pink, and Purple** wires should **NOT** be connected at this point. (LED Driver will sit inside of J-Box)

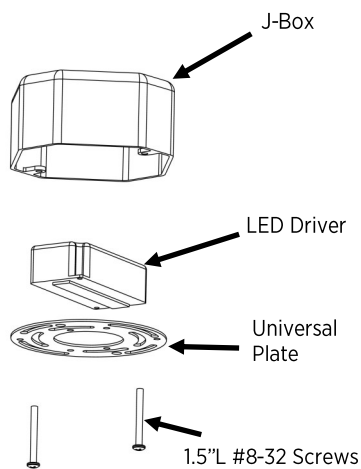

## Step 4

- 1) Feed exposed wire end of pendant assembly up through the cord grip on the canopy until the desired length of cord is left between the canopy and light body.
- 2) Using a flat blade screw driver tighten the cord grip to secure pendant. **DO NOT OVER TIGHTEN. THIS MAY DAMAGE THE FIXTURE.**
- 3) Using wire cutters/strippers trim excess cord. (Take into account a minimum of 6" of cord will be required for making the wire connections in the J-Box)

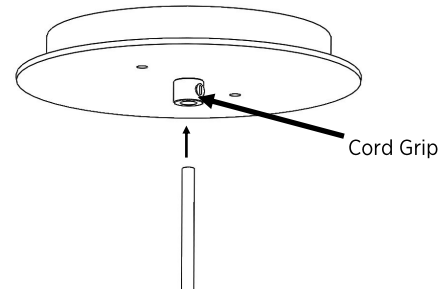

## Step 5

Make wire connections from the Pendant assembly to the LED Driver. The Pendant will have a **WHITE** and **BLACK** wire and the LED Driver will have a **RED** and **BLUE** wire.

- 1) Connect the **WHITE** wire from the pendant assembly to the **RED** wire of the LED Driver using one of the provided Orange wire nuts.
- 2) Connect the **BLACK** wire from the pendant assembly to the **BLUE** wire (right next to the red wire) of the LED Driver using one of the provided Orange wire nuts.

**NOTE:** The **PINK** and **PURPLE** wires are used for optional 0-10V dimming. If not applicable, cap each of the wires.

## Step 6

Mount the canopy to the ceiling using the **Mounting Instructions** provided within Hardware Pack Y.

## Step 7

Attach the glass to the LED pendant housing by screwing glass into LED housing.

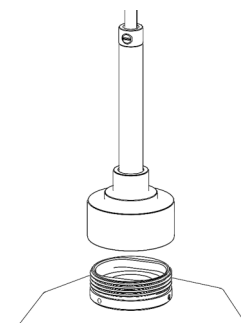

Tighten till snug  
**DO NOT** overtighten

# Warranty

---

Please visit <https://studio.hammerton.com/lifetime-limited-warranty/> to view the Hammerton Studio Warranty Policy.

# About Hammerton Studio

---

## HAMMERTON STUDIO

When we introduced the Hammerton Studio brand in 2014, we saw an enormous opportunity to raise the bar in decorative lighting. In design, we wanted to lead rather than follow. In construction, we wanted to showcase Hammerton's renowned reverence for time-honored artisan craftsmanship and authentic materials. In performance, we wanted to provide highly reliable solutions that far exceeded industry norms for aesthetics, function, and quality. Based on the brand's dramatic growth and customer feedback, it's clear we are on the right track.

## EXTRAORDINARY DESIGN VALUE IN ARTISAN GLASS & METALWORK

Hammerton began in 1995 as a blacksmith shop, but we've come a long way since then. Today we employ a world class team of metal artisans who are disciplined in a broad range of fabrication techniques and processes. We've also added in-house capabilities in blown, cast and kiln-fused glass, and today Hammerton operates one of the largest artisan glass production facilities in the U.S. With deep design and fabrication expertise at the intersection of glass and metalwork, we're laying the foundation for a new era of lighting innovation.

## THE HAMMERTON HERITAGE

Our Hammerton Studio brand stands on the shoulders of more than a quarter century of experience pushing the boundaries of innovative custom lighting design. Each Hammerton Studio collection has been inspired by custom work our company has brought to life in collaboration with leading interior design professionals over the years. Built to your specifications, every fixture reflects the uncompromising design and attention to detail that is distinctly Hammerton.

## A REPUTATION REFLECTED BY OUR CLIENTS

Hammerton fixtures are as extraordinary as the clients who purchase them, including Forbes 400 members, Fortune 500 leaders, award-winning entertainers, fashion and interior designers, sports legends, and leading luxury hospitality brands.

Hammerton Inc.  
217 Wright Brothers Drive  
Salt Lake City, UT 84116

801-973-8095 EXT: 4  
[www.hammerton.com](http://www.hammerton.com)