

Step 12: Push the lightbar end into the end housing (E) until you can hear the detent snap into place. Repeat this for the center housing (D). Once light bar is in place, tighten set screw from the top access hole using the .050" Allen key until the screw bottoms out.

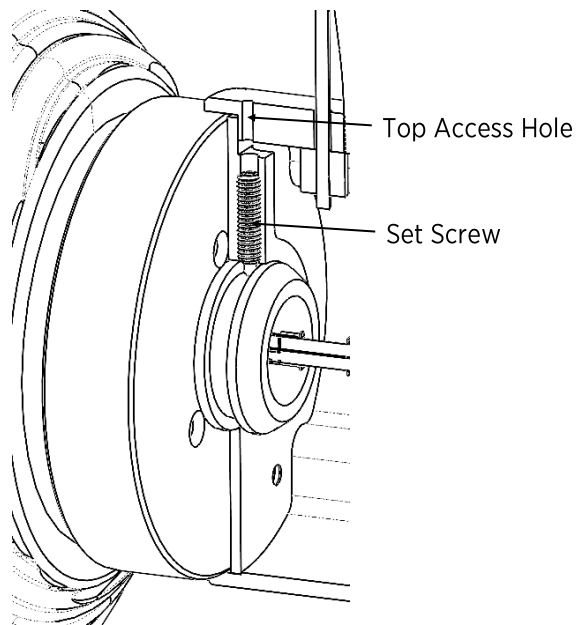

Step 13: Make any final adjustments to aircraft cable in the canopies to ensure the lightbars are level. Once fixture is in place, use cable grippers to snip off any excess aircraft cable.

Step 14: Snip the coaxial wire in the canopy so that 10" length of wire is available in the canopy. Strip outer sheath of coaxial cable off, and twist outer conductor together. Attach outer conductor (-) to the purple wire (-) on the driver. Strip and attach inner conductor (+) to red wire (+) on driver. Place the cover back onto the canopy. Use the provided plastic clips to connect the coaxial power wire to the aircraft cable, clipping them on roughly every foot.

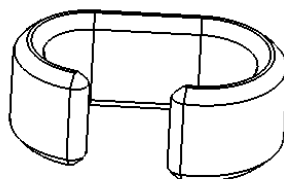

Clear Cable Clip for wire management

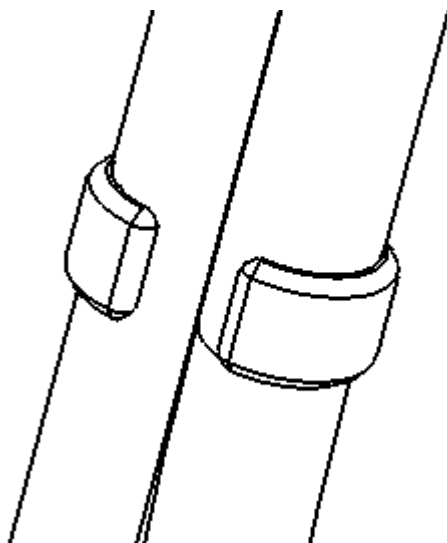

Install Cable clip on coax wire first then clip to the aircraft cable

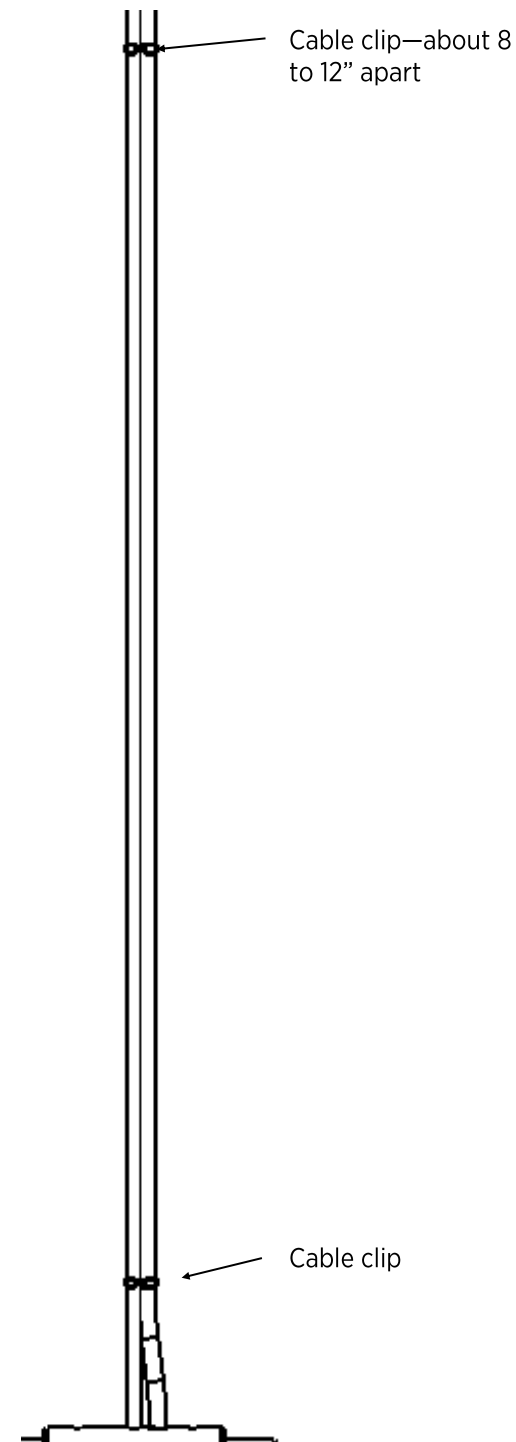

Step 7: Connect the end housings (E) to the cable grippers by inserting the aircraft cable into the cable gripper. Adjust all three housings to the desired height by pushing the aircraft cable further into the gripper. They should all be at the same height.

Note: If the aircraft cable is pushed too far into the gripper push up on the gripper to release tension on the cable and pull back through the gripper.

Step 8: Remove the light bar end cap from one side by unscrewing the three countersunk screws using the provided 2mm Allen key.

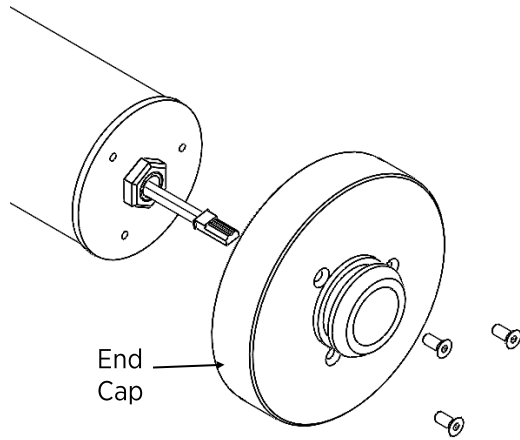

Step 9: With one end cap removed, place glass and spacers according to the image to the right, ensuring that a silicone washer is placed between each component. Once all glass and spacers are in place, re-attach end cap.

Note: Do not over tighten the 3 small screws that hold the end cap onto the light bar

Step 9:

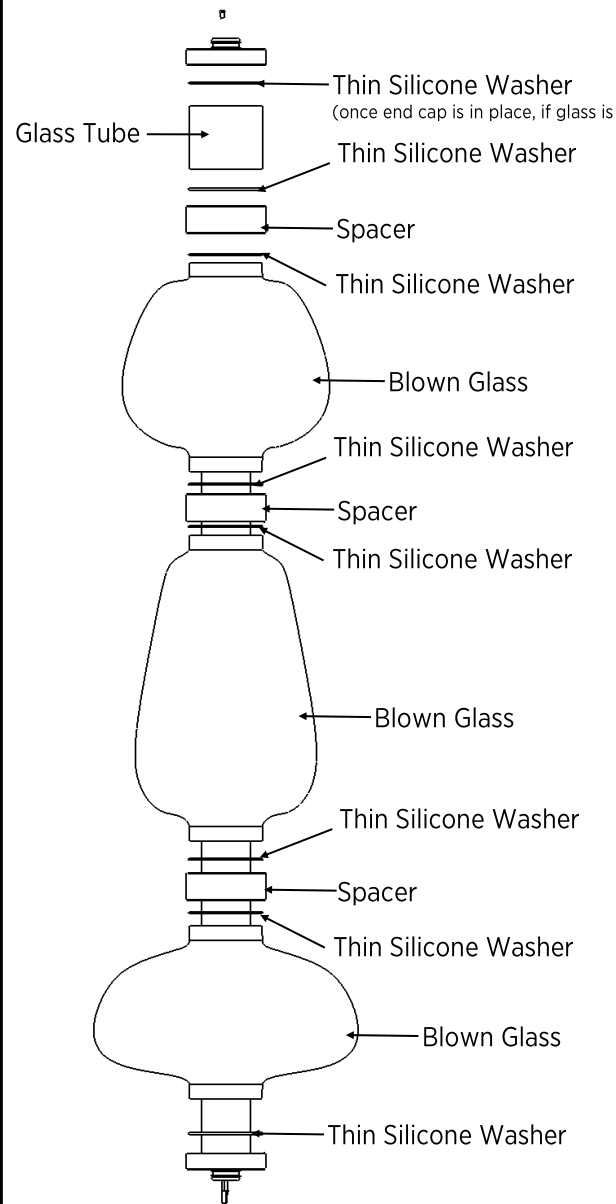

Step 10: Make sure the spring plungers on both the center and end housings have only the detent shown. If you see threads, back this out using the .050" Allen Wrench until only the detent is shown.

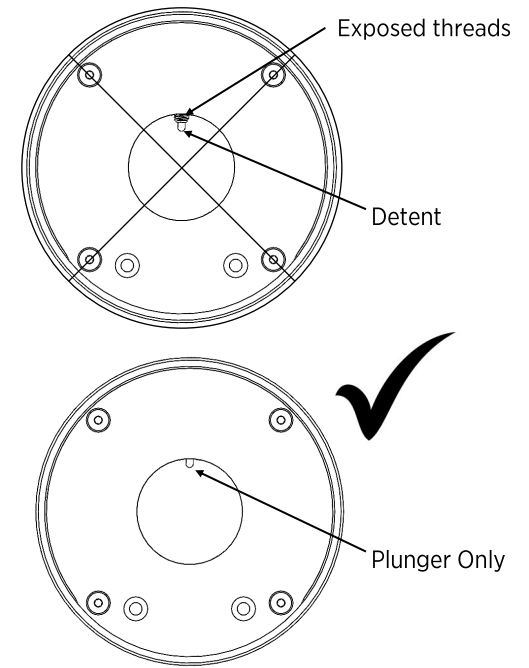

Step 11: Bring the assembled light bar up to the end housing and make the electrical connection by plugging in the male end of the red connector to the female end. Once the electrical connection is made push wires into the end housing

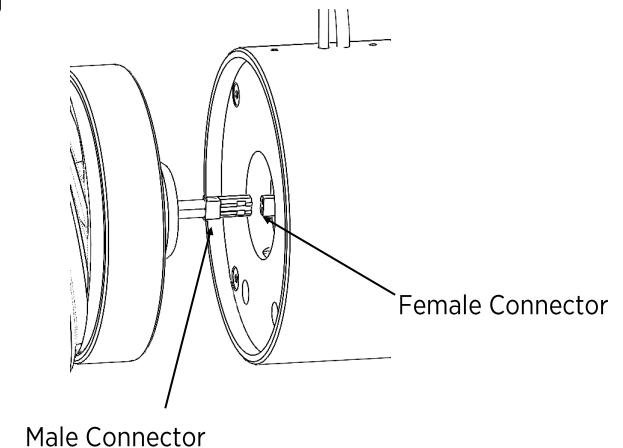

Included Components

- A. Hardware Pack T, with Instructions
- B. Canopy
- C. Satellite cable gripper
- D. Center Housing with aircraft cable and coaxial power cable
- E. End Housing with aircraft cable
- F. Light Bar (Hidden behind blown glass)
- G. Blown Glass
- H. Glass Spacers
- I. Glass Tube

Required Tools

- 1. Phillips screw driver (not provided)
- 2. Wire cutters/strippers (not provided)
- 3. Cable cutters (not provided)
- 4. 2mm Allen Wrench (included)
- 5. .050" Allen Wrench (included)

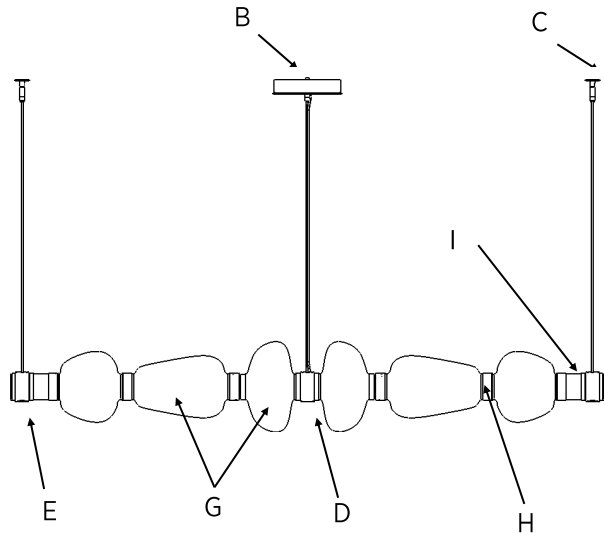

Example Fixture: PLB0094-06

Assembly Instructions

Step 1: Remove the faceplate from Canopy (B) by pulling the faceplate, which is connected by magnets, off of the canopy.

Step 2: Mount Canopy (B) to ceiling using Hardware Packet T (A) and included instructions.

HARDWARE PACKET T: MOUNTS TO J-BOX

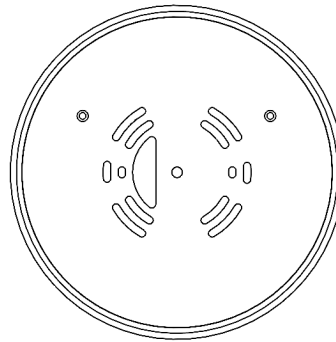

Warning: Source Power should be turned off. Failing to do so may result in damage to the fixture.

Step 3: Make wire connections to source power, connecting white wire to white wire (Neutral) and Black wire to Black wire (hot).

Step 4: Run the aircraft cable and coaxial power cable of the Center Housing (D.) through the faceplate then insert the aircraft cable into the canopy cable gripper. Leave the coaxial power cable disconnected.

Step 5: Measure out and mark 35" from the center of the J-box in both directions. This is the mounting location for the Satellite cable grippers.

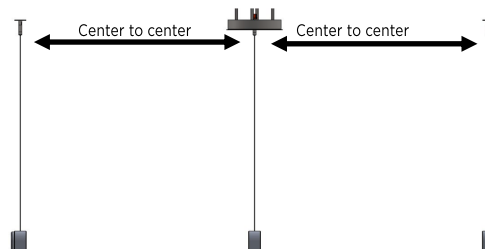

Step 6: Once the mounting location is identified, screw the provided toggle bolt body into the drywall using a Phillips head screw driver (see E-Z Toggle instructions below). Once the toggle bolt body is in place, run the provided toggle bolt screw through the satellite cable gripper then screw into the toggle bolt body until it is secured firmly in place. Repeat for the other side.

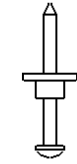

The bottom adapter of the satellite gripper gets held to the ceiling with the screw from the EZ Toggle

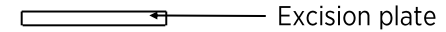

Excision plate

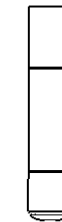

Unscrew the top of the satellite gripper

E-Z Toggle™ Instructions

Turn E-Z Toggle into drywall until seated flush. Arrows on head indicate direction toggle clamp will open. End with arrows up and down.

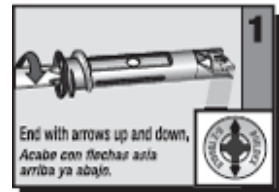

Place fixture over E-Z Toggle. Push screw into E-Z Toggle to engage clamp

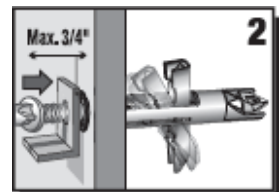

Turn screw until it stops. Toggle clamp tightens against drywall as screw is turned.

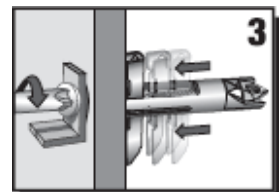

About Hammerton Studio

HAMMERTON STUDIO

When we introduced the Hammerton Studio brand in 2014, we saw an enormous opportunity to raise the bar in decorative lighting. In design, we wanted to lead rather than follow. In construction, we wanted to showcase Hammerton's renowned reverence for time-honored artisan craftsmanship and authentic materials. In performance, we wanted to provide highly reliable solutions that far exceeded industry norms for aesthetics, function, and quality. Based on the brand's dramatic growth and customer feedback, it's clear we are on the right track.

EXTRAORDINARY DESIGN VALUE IN ARTISAN GLASS & METALWORK

Hammerton began in 1995 as a blacksmith shop, but we've come a long way since then. Today we employ a world class team of metal artisans who are disciplined in a broad range of fabrication techniques and processes. We've also added in-house capabilities in blown, cast and kiln-fused glass, and today Hammerton operates one of the largest artisan glass production facilities in the U.S. With deep design and fabrication expertise at the intersection of glass and metalwork, we're laying the foundation for a new era of lighting innovation.

THE HAMMERTON HERITAGE

Our Hammerton Studio brand stands on the shoulders of more than a quarter century of experience pushing the boundaries of innovative custom lighting design. Each Hammerton Studio collection has been inspired by custom work our company has brought to life in collaboration with leading interior design professionals over the years. Built to your specifications, every fixture reflects the uncompromising design and attention to detail that is distinctly Hammerton.

A REPUTATION REFLECTED BY OUR CLIENTS

Hammerton fixtures are as extraordinary as the clients who purchase them, including Forbes 400 members, Fortune 500 leaders, award-winning entertainers, fashion and interior designers, sports legends, and leading luxury hospitality brands.

Hammerton Inc.
217 Wright Brothers Drive
Salt Lake City, UT 84116

801-973-8095 EXT: 4
www.hammerton.com

Warranty

Please visit:
<https://studio.hammerton.com/lifetime-limited-warranty/>
to view the Hammerton Studio Warranty Policy

HAMMERTONSTUDIO™

Assembly Instructions

PLB0094-06 Bolla Linear

Image below is a representation of applicable product collection

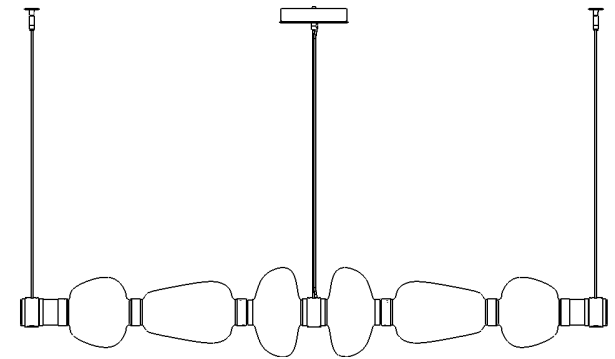

PLB0094-06

**WARNING: FAILURE TO INSTALL THIS
FIXTURE PROPERLY MAY RESULT IN
SERIOUS PERSONAL INJURY OR DEATH
AND PROPERTY DAMAGE.**

It is recommended that this product be installed
by a licensed electrician.

41-001-00275
Rev 2