

About Hammerton Studio

HAMMERTON STUDIO

When we introduced the Hammerton Studio brand in 2014, we saw an enormous opportunity to raise the bar in decorative lighting. In design, we wanted to lead rather than follow. In construction, we wanted to showcase Hammerton's renowned reverence for time-honored artisan craftsmanship and authentic materials. In performance, we wanted to provide highly reliable solutions that far exceeded industry norms for aesthetics, function, and quality. Based on the brand's dramatic growth and customer feedback, it's clear we are on the right track.

EXTRAORDINARY DESIGN VALUE IN ARTISAN GLASS & METALWORK

Hammerton began in 1995 as a blacksmith shop, but we've come a long way since then. Today we employ a world class team of metal artisans who are disciplined in a broad range of fabrication techniques and processes. We've also added in-house capabilities in blown, cast and kiln-fused glass, and today Hammerton operates one of the largest artisan glass production facilities in the U.S. With deep design and fabrication expertise at the intersection of glass and metalwork, we're laying the foundation for a new era of lighting innovation.

THE HAMMERTON HERITAGE

Our Hammerton Studio brand stands on the shoulders of more than a quarter century of experience pushing the boundaries of innovative custom lighting design. Each Hammerton Studio collection has been inspired by custom work our company has brought to life in collaboration with leading interior design professionals over the years. Built to your specifications, every fixture reflects the uncompromising design and attention to detail that is distinctly Hammerton.

A REPUTATION REFLECTED BY OUR CLIENTS

Hammerton fixtures are as extraordinary as the clients who purchase them, including Forbes 400 members, Fortune 500 leaders, award-winning entertainers, fashion and interior designers, sports legends, and leading luxury hospitality brands.

Hammerton Inc.
217 Wright Brothers Drive
Salt Lake City, UT 84116

801-973-8095 EXT: 4
www.hammerton.com

Warranty

Please visit:
<https://studio.hammerton.com/lifetime-limited-warranty/>
to view the Hammerton Studio Warranty Policy

HAMMERTONSTUDIO™

Assembly Instructions

IDB0XXX-D2 "Mandrel Sconce"

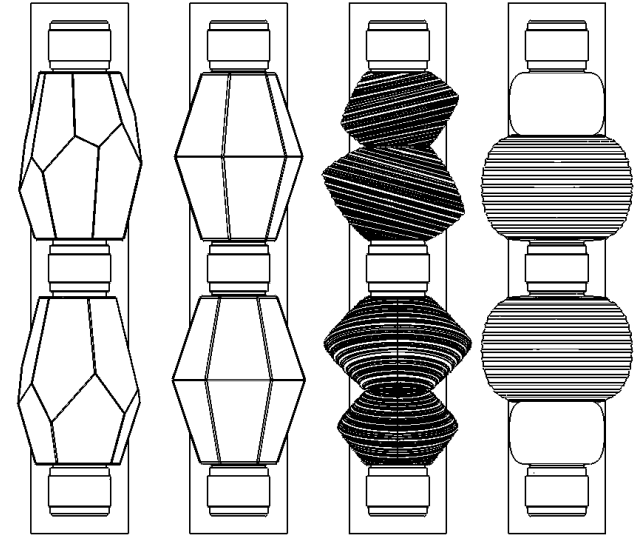

IDB0039-D2
"Gem"

IDB0049-D2
"Aalto"

IDB0089-D2
"Mesa"

IDB0106-D2
"Torno"

WARNING: Failure to use the LED driver to power your pendant will permanently damage your product making it unusable.

WARNING: FAILURE TO INSTALL THIS FIXTURE PROPERLY MAY RESULT IN SERIOUS PERSONAL INJURY OR DEATH AND PROPERTY DAMAGE.

It is recommended that this product be installed by a licensed electrician.

Included Components

- A. Hardware Packet U with Instructions
- B. Blown Glass
- C. Ceramic (Torno only)
- D. Silicone Spacers
- E. Light Bar
- F. Canopy
- G. End Caps
- H. JST Connector

Required Tools

1. Philips screw driver (not provided)
2. Wire cutters/strippers (not provided)
3. Measuring tape (not provided)
4. 9/16in Wrench (not provided)

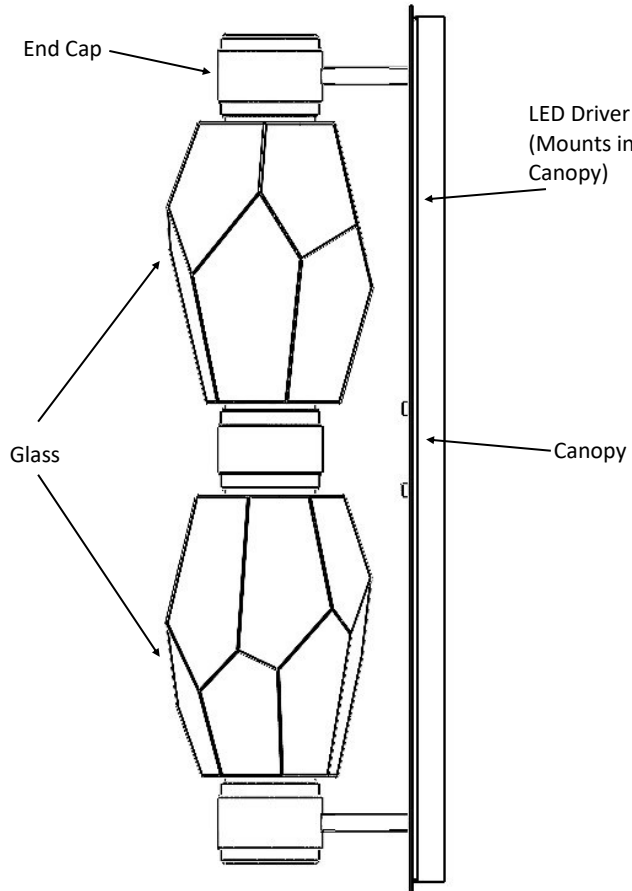

Example fixture IDB0039-D2 shown

Assembly Instructions

Step 1: TURN OFF POWER TO JUNCTION BOX TO BE USED FOR INSTALLATION.

WARNING: Failure to use the LED driver to power your pendant will permanently damage your product making it unusable

Step 2: Remove one side of the Glass Tube Retention by unscrewing the Three Phillips screws.

Step 3: Place alternating glass, and spacers according to the image shown ensuring that a silicone gasket is placed between each interface of materials. See cover page for suggested part arrangement. Due to variation in glass size it may be necessary to stack a few gaskets to the last connection to ensure there is compression when the machined end is placed back onto the light tube. Screw the end back on with the three Phillips screws to complete the lightbar assembly.

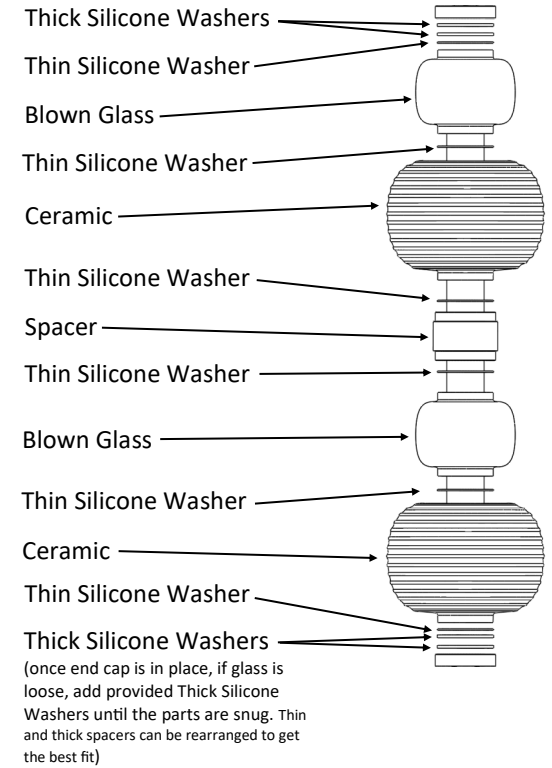
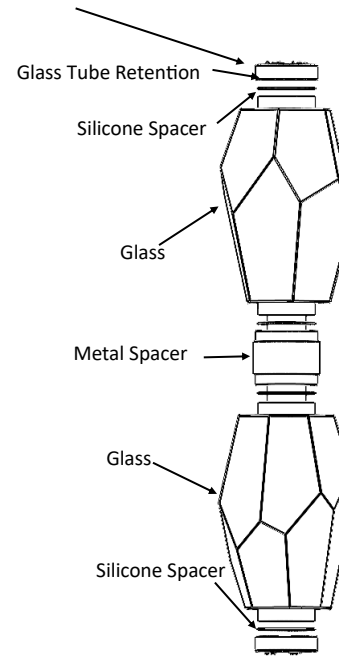

Step 4: Thread the female JST connector through the connecting rod of an end cap, and connect to male JST of light bar.

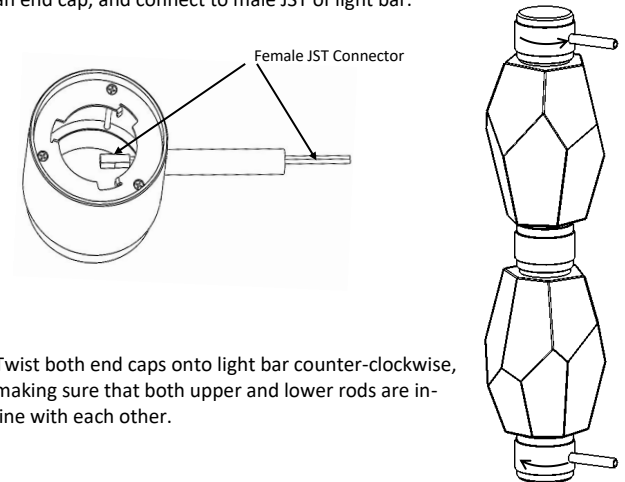

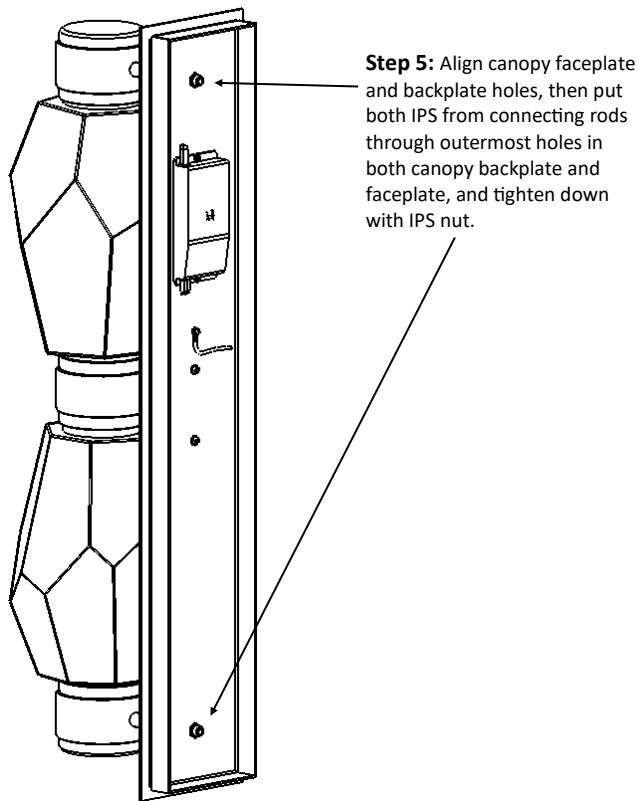

Step 6: Mount the universal plate to J-Box using only 2 of the 1.5" L #8-32 screws provided in the mounting pack. Make 120 VAC connections from the power source to the driver using the Black and White wires. Using provided wire nuts, connect the red wire of the Female JST to the Red (+) wire on the driver and the black wire of the JST to the Purple (-) wire on the driver. Connect the house's ground wire to both the ground wire of the driver and the provided copper ground connection.

Step 7: Mount fixture according to Mounting Pack U instructions.