

About Hammerton Studio

HAMMERTON STUDIO

When we introduced the Hammerton Studio brand in 2014, we saw an enormous opportunity to raise the bar in decorative lighting. In design, we wanted to lead rather than follow. In construction, we wanted to showcase Hammerton's renowned reverence for time-honored artisan craftsmanship and authentic materials. In performance, we wanted to provide highly reliable solutions that far exceeded industry norms for aesthetics, function, and quality. Based on the brand's dramatic growth and customer feedback, it's clear we are on the right track.

EXTRAORDINARY DESIGN VALUE IN ARTISAN GLASS & METALWORK

Hammerton began in 1995 as a blacksmith shop, but we've come a long way since then. Today we employ a world class team of metal artisans who are disciplined in a broad range of fabrication techniques and processes. We've also added in-house capabilities in blown, cast and kiln-fused glass, and today Hammerton operates one of the largest artisan glass production facilities in the U.S. With deep design and fabrication expertise at the intersection of glass and metalwork, we're laying the foundation for a new era of lighting innovation.

THE HAMMERTON HERITAGE

Our Hammerton Studio brand stands on the shoulders of more than a quarter century of experience pushing the boundaries of innovative custom lighting design. Each Hammerton Studio collection has been inspired by custom work our company has brought to life in collaboration with leading interior design professionals over the years. Built to your specifications, every fixture reflects the uncompromising design and attention to detail that is distinctly Hammerton.

A REPUTATION REFLECTED BY OUR CLIENTS

Hammerton fixtures are as extraordinary as the clients who purchase them, including Forbes 400 members, Fortune 500 leaders, award-winning entertainers, fashion and interior designers, sports legends, and leading luxury hospitality brands.

Hammerton Inc.
217 Wright Brothers Drive
Salt Lake City, UT 84116

801-973-8095 EXT: 4
www.hammerton.com

Warranty

Please visit:
<https://studio.hammerton.com/lifetime-limited-warranty/>
to view the Hammerton Studio Warranty Policy

HAMMERTONSTUDIO™

Assembly Instructions

LAB0XXX-02 "Mandrel"

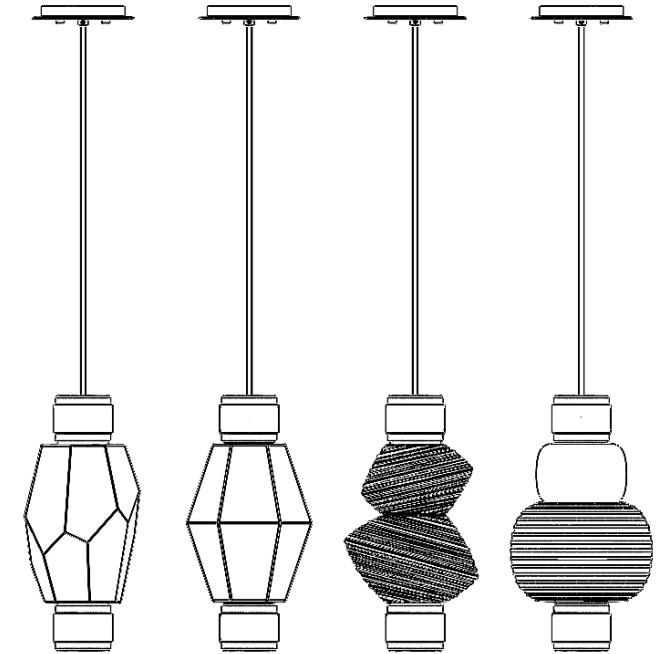

LAB0039-D1
"Gem"

LAB0089-D1
"Mesa"

LAB0049-D1
"Aalto"

LAB0106-D1
"Torno"

WARNING: Failure to use the LED driver to power your pendant will permanently damage your product making it unusable.

WARNING: FAILURE TO INSTALL THIS FIXTURE PROPERLY MAY RESULT IN SERIOUS PERSONAL INJURY OR DEATH AND PROPERTY DAMAGE.

It is recommended that this product be installed by a licensed electrician.

Included Components

- Hardware Packet Y with Instructions
- Blown Glass
- Ceramic (Torno only)
- Canopy
- Cloth Braided Cord

Required Tools

- Philips screw driver (not provided)
- Wire cutters/strippers (not provided)
- Measuring tape (not provided)

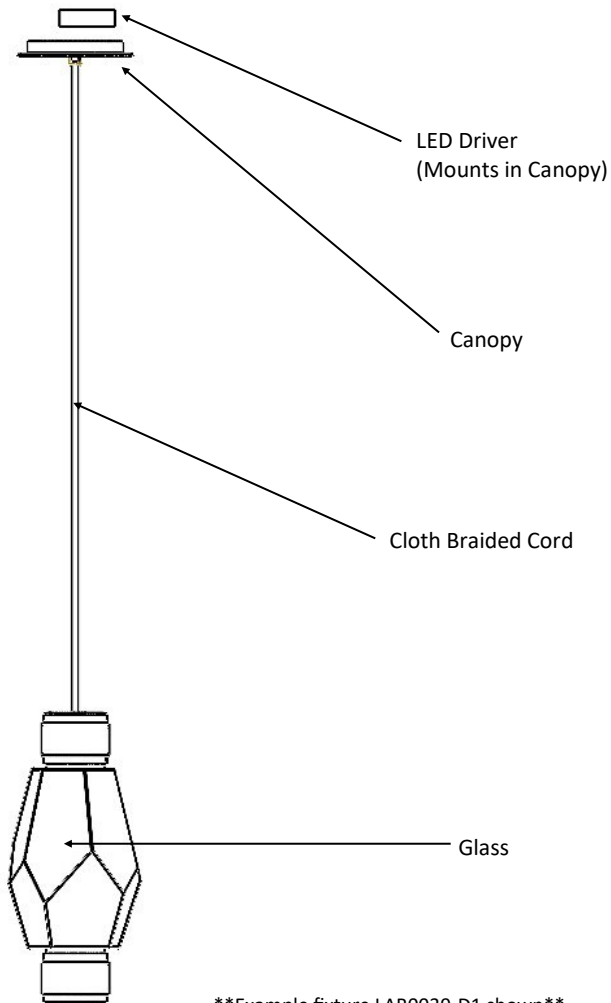

Example fixture LAB0039-D1 shown

Assembly Instructions

Step 1: TURN OFF POWER TO JUNCTION BOX TO BE USED FOR INSTALLATION.

WARNING: Failure to use the LED driver to power your pendant will permanently damage your product making it unusable

Step 2: Make 120 VAC connections from the power source to the driver using the Black and White wires. The Red and Purple leads should not be connected at this point. Place driver inside of the junction box, then install universal plate if j-box does not have one already.

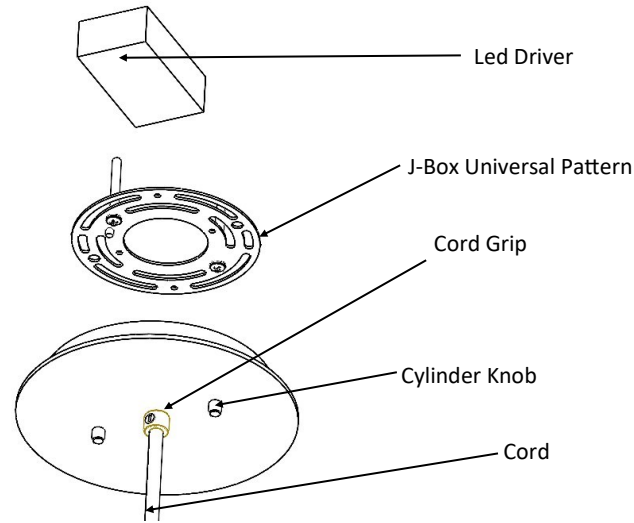

Step 3: Remove the bottom housing of the light by twisting the housing to clockwise and disconnecting the wire connection. Remove the three screws holding the bottom cap to the light bar.

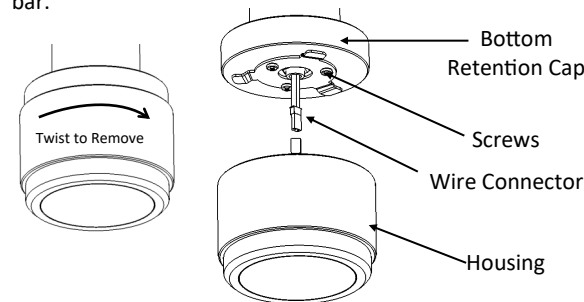

Step 4: Assemble Blown Glass to fixture (glass appearance may vary depending on fixture type) ensuring that a silicone gasket is placed between each interface of materials. See cover page for suggested part arrangement. Due to variation in glass size it may be necessary to stack a few gaskets before re-installing retention cap to ensure there is compression. Screw the retention cap on with the three screws to secure glass.

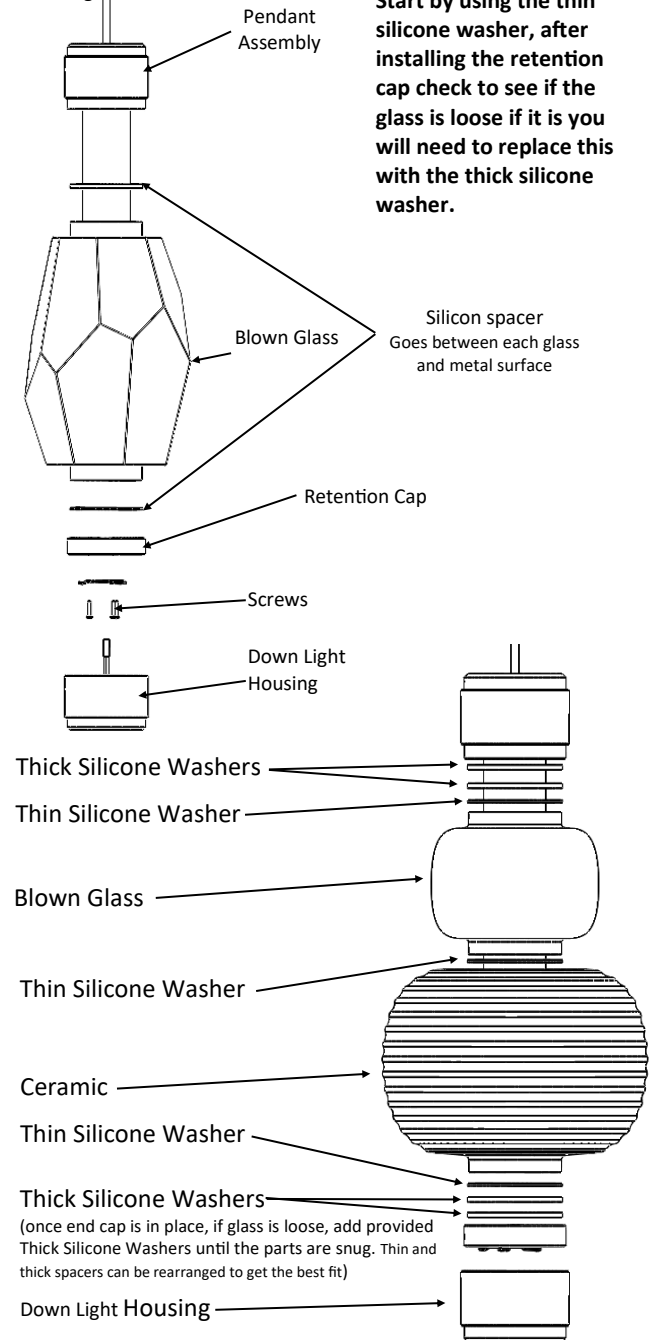

Step 5: Reinstall lower section of the light, making sure to reconnect wire connection. Feed exposed wire end of pendant assembly up through the cord grip on the canopy until the desired length of cord is left between the canopy and light body. Using a flat blade screw driver tighten the cord grip to secure pendant then use a torque wrench to tighten to 10 in/lbs. DO NOT OVER TIGHTEN. THIS MAY DAMAGE THE FIXTURE. Using wire cutters/strippers trim excess cord.

Step 6: Make wire connections from the Pendant assembly to the LED Driver. The Pendant will have a WHITE and BLACK wire and the LED Driver will have a RED and PURPLE wire. Connect the WHITE wire from the pendant assembly to the RED wire of the LED Driver using one of the provided Orange wire nuts. Connect the BLACK wire from the pendant assembly to the PURPLE wire of the LED Driver using one of the provided Orange wire nuts.

Step 7: Install canopy by first twisting the all threads into the Universal Plate, putting the canopy faceplate and backplate over the all threads, and pinning the canopy up against the ceiling by twisting the cylinder knobs over the all threads.