

About Hammerton Studio

HAMMERTON STUDIO

In 2013, the Hammerton Studio brand was created to offer artisan-crafted, contemporary design solutions that are both versatile and accessible. Hammerton Studio fixtures add contemporary distinction to entries, great rooms and master suites, yet are cost-effective enough to use throughout any residential or commercial projects. Like all Hammerton fixtures, they are designed and fabricated in Salt Lake City, Utah using domestically sourced materials.

POWERFUL DESIGN

Since 1992, Hammerton has been known for extraordinary decorative lighting that is boldly designed, expertly rendered, perfectly proportioned and exquisitely detailed. Each fixture exudes a design aesthetic that is timeless and enduring, yet remarkably relevant.

UNCOMPROMISING CRAFTSMANSHIP

In addition to their exceptional metalworking and finishing expertise, Hammerton artisans share an aesthetic eye and a sculptural talent that define the difference between ordinary and extraordinary craftsmanship. Every fixture demonstrates its artisan's ability to elevate craft to an art form.

UNIQUE MATERIALS

Our heritage is in metal fabrication, but our passion is design. As a result—and unlike most of our peers—we work in a broad palette of materials: steel and aluminum, blown, kiln-fired and lampworked glass, acrylics, mica, stone, rawhide, woods and much more. Seamless integration of these capabilities is the "secret sauce" that drives our industry leadership as the premier U.S. based custom lighting manufacturer.

A REPUTATION REFLECTED BY OUR CLIENTS

Hammerton fixtures are as extraordinary as the clients who purchase them, including Forbes 400 members, Fortune 500 leaders, award-winning entertainers, fashion and interior designers, sports legends, and leading luxury hospitality brands.

Hammerton
217 Wright Brothers Drive
Salt Lake City, UT
84116

801-973-8095
info@hammerton.com
www.hammerton.com

Warranty

Please visit:

<https://studio.hammerton.com/lifetime-limited-warranty/>

to view the Hammerton Studio Warranty Policy

HAMMERTONSTUDIO™

Assembly Instructions

CHB0XXX-D3 "Mandrel"

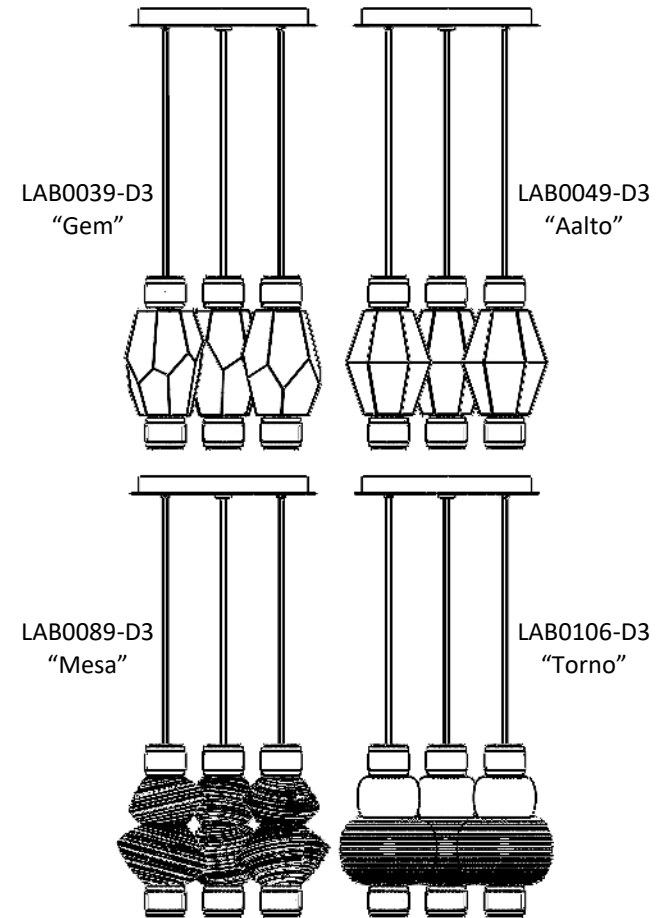

WARNING: Failure to use the LED driver to power your pendant will permanently damage your product making it unusable.

WARNING: FAILURE TO INSTALL THIS FIXTURE PROPERLY MAY RESULT IN SERIOUS PERSONAL INJURY OR DEATH AND PROPERTY DAMAGE.

It is recommended that this product be installed by a licensed electrician who is familiar with proper LED installation and electrical loads.

Rev 6
41-001-00289

Included Components

- A. Hardware Packet W, with Instructions
- B. Blown Glass (QTY:3)
- C. Ceramic (QTY:3 — Torno only)
- D. Canopy
- E. Light Bodies With Cord (QTY:3)
- F. Cord grip (QTY:3 — Attached to canopy)
- G. Flat Cap

Required Tools

1. Philips screw driver (not provided)
2. Wire cutters/strippers (not provided)
3. Measuring tape (not provided)

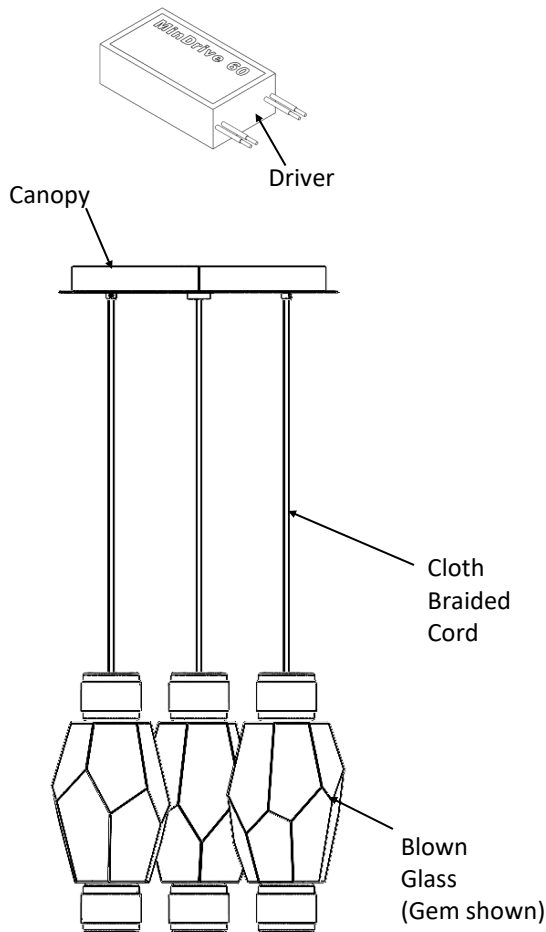

Assembly Instructions

Step 1: TURN OFF POWER TO JUNCTION BOX PRIOR TO INSTALLATION.

WARNING: Failure to use the LED driver to power the pendants will permanently damage your product making it unusable

Step 2: Loosen the cord grip set screws and feed the braided fabric cord into the canopy until the desired amount of cord is left between the canopy and light body. Take into account that a minimum of 6" of cord will be required for connecting the wiring to the driver.

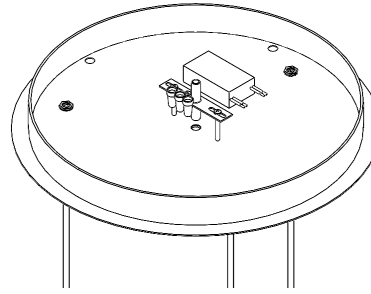

Step 3: Use a measuring tape to be sure that all of the pendants are hanging the desired distance from the canopy. Tighten the cord grips on the face of the canopy using a flat blade screw driver to secure pendants in place. **DO NOT OVER TIGHTEN. THIS MAY DAMAGE THE FIXTURE.**

Step 4: Cut wires to length and make connections to the Driver. Braided fabric cord must be wired to the Driver in parallel, **All Black to Purple Driver Wire and All White to Red Driver Wire.**

WARNING

DO NOT DIRECTLY CONNECT LEDs TO AC POWER. LEDs will be damaged if exposed to high voltages.

Step 5: Install the canopy by following **Mounting Packet W Instructions.**

Step 6: Remove the bottom housing of the light by twisting the housing to clockwise and disconnecting the wire connection. Remove the three screws holding the bottom cap to the light bar.

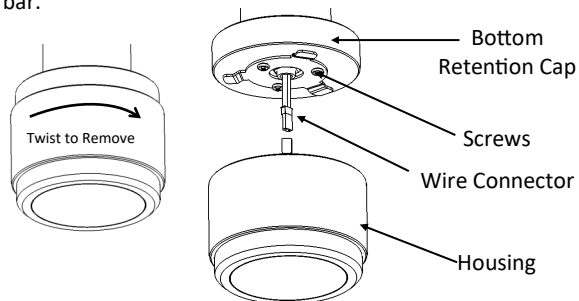

Step 7: Assemble Blown Glass to fixture (glass appearance may vary depending on fixture type) ensuring that a silicone gasket is placed between each interface of materials. See cover page for suggested part arrangement. Due to variation in glass size it may be necessary to stack a few gaskets before re-installing retention cap to ensure there is compression. Screw the retention cap on with the three screws to secure glass.

