

## About Hammerton Studio

---

### HAMMERTON STUDIO

When we introduced the Hammerton Studio brand in 2014, we saw an enormous opportunity to raise the bar in decorative lighting. In design, we wanted to lead rather than follow. In construction, we wanted to showcase Hammerton's renowned reverence for time-honored artisan craftsmanship and authentic materials. In performance, we wanted to provide highly reliable solutions that far exceeded industry norms for aesthetics, function, and quality. Based on the brand's dramatic growth and customer feedback, it's clear we are on the right track.

### EXTRAORDINARY DESIGN VALUE IN ARTISAN GLASS & METALWORK

Hammerton began in 1995 as a blacksmith shop, but we've come a long way since then. Today we employ a world class team of metal artisans who are disciplined in a broad range of fabrication techniques and processes. We've also added in-house capabilities in blown, cast and kiln-fused glass, and today Hammerton operates one of the largest artisan glass production facilities in the U.S. With deep design and fabrication expertise at the intersection of glass and metalwork, we're laying the foundation for a new era of lighting innovation.

### THE HAMMERTON HERITAGE

Our Hammerton Studio brand stands on the shoulders of more than a quarter century of experience pushing the boundaries of innovative custom lighting design. Each Hammerton Studio collection has been inspired by custom work our company has brought to life in collaboration with leading interior design professionals over the years. Built to your specifications, every fixture reflects the uncompromising design and attention to detail that is distinctly Hammerton.

### A REPUTATION REFLECTED BY OUR CLIENTS

Hammerton fixtures are as extraordinary as the clients who purchase them, including Forbes 400 members, Fortune 500 leaders, award-winning entertainers, fashion and interior designers, sports legends, and leading luxury hospitality brands.

Hammerton Inc.  
217 Wright Brothers Drive  
Salt Lake City, UT 84116

801-973-8095 EXT: 4  
[www.hammerton.com](http://www.hammerton.com)

## Warranty

---

Please visit:  
<https://studio.hammerton.com/lifetime-limited-warranty/>  
to view the Hammerton Studio Warranty Policy

# HAMMERTONSTUDIO™

## Assembly Instructions

### Tessera Multi-Pendant

*Image below is a representation of applicable product collection*

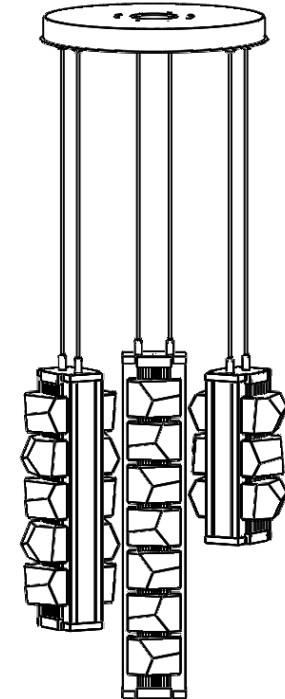

CHB0100

**WARNING:** FAILURE TO INSTALL THIS FIXTURE PROPERLY MAY RESULT IN SERIOUS PERSONAL INJURY OR DEATH AND PROPERTY DAMAGE.

It is recommended that this product be installed by a licensed electrician.

41-001-00293  
Rev 3

## Included Components

- A. Hardware Packet R, with Instructions
- B. Canopy
- C. Canopy Face Plate
- D. Cable Stops
  - D1. Cap
  - D2. Bushing
  - D3. Bushing
- E. Cables
- F. Cable Grippers
  - F1. Cap
  - F2. Body
- G. Pendant Light Bodies
  - G1. 12" Pendant Light Body (QTY: 2 for 5 light option)
  - G2. 18" Pendant Light Body (QTY: 2 for 5 light option)
  - G3. 24" Pendant Light Body
- H. Pendant Top Cover Plate
  - H1. Pendant Top Cover Plate Screw
- I. Cast Glass
- J. Glass Spacers

## Required Tools

1. Phillips screw driver (not provided)
2. Wire cutters/strippers (not provided)
3. Measuring tape (not provided)
4. Level (not provided)
5. 5/16" open-end or adjustable wrench (not provided)

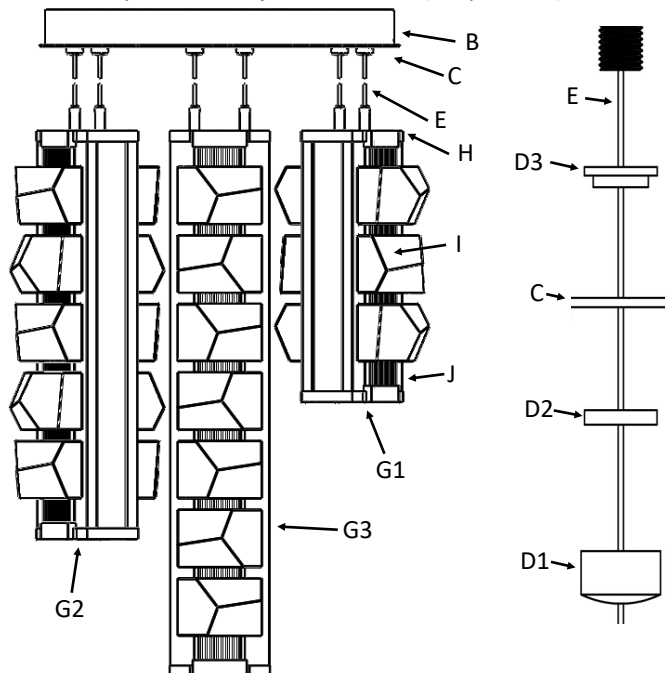

Example Fixture Shown: CHB0100-03

## Assembly Instructions

**Step 1:** Remove Face Plate (C) From Canopy (B) by unscrewing the Cable Stop Caps (D1). The Caps (D1), Face Plate (C), and Bushings (D2, D3) will slide down cables (E).

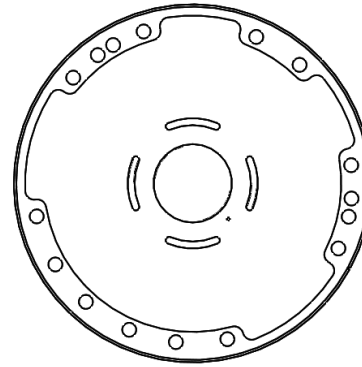

**Step 2:** Mount Canopy (B) to ceiling using the appropriate Hardware Packet (A) and included instructions.

**Warning:** Source Power should be turned off. Failing to do so may result in damage to the fixture.

**Step 3:** Make wire connections to source power connecting white wire to white wire (Neutral) and Black wire to Black wire (hot).

**Step 4:** Replace Bushings (D2, D3), Face Plate (C), and Caps (D1).

**Step 5:** Cables (E) and Cable Grippers (F) are marked by a numbered tag (e.g. 1-1). Each Cable (E) will be inserted into the Cable Gripper (F) marked with the same number.

**Step 6:** After locating the corresponding Cable (E) and Cable Gripper (F), unscrew the pendant top plate screw (H1) and remove the top cover plate (H). Unscrew the Cable Gripper Caps (F1). Thread the Cable (E) through the Cover Plate (H) and Caps (F1) and into the Gripper Bodies (F2). Rest the Top Cover Plate (H) on top of the light body, but wait to replace the screw.

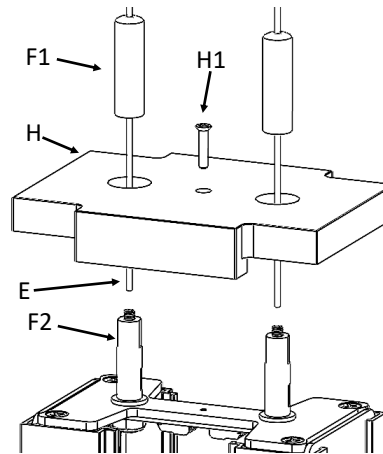

**Step 7:** Use a measuring tape and level to ensure the fixture is hanging at the desired distance from the Canopy. When desired height is attained cut excess Cable flush with Gripper Body. Thread Cable Gripper Cap back onto Body.

**CAUTION:** CABLES ARE CONDUCTIVE. DO NOT POWER FIXTURE WHILE CABLES ARE IN CONTACT WITH ANY CONDUCTIVE SURFACE. THIS INCLUDES HAVING THE CABLE PROTRUDE THROUGH THE GRIPPER AND TOUCH THE BODY OF THE LIGHT FIXTURE.

**Step 8:** Lifting the Top Cover Plate (H) from the light bodies (G), Install Glass Spacers (J) and Cast Glass (I) by sliding them into the interlocking grooves in the light bodies. Install the larger spacers on the top and bottom of the fixture, and use the smaller spacers between each glass piece. Alternate direction of cast glass pieces as desired. Replace the Top Cover Plate (H) using the screw removed previously (H1). If installing a Tetro option multi-pendant, be sure to install the smaller pieces of glass first, then alternate with larger pieces.

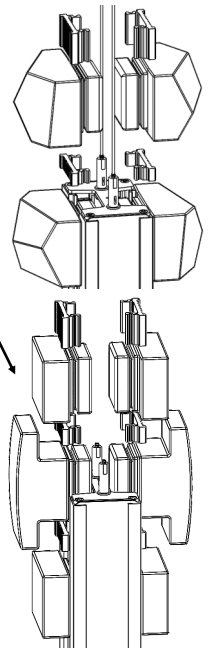

**Step 9:** If Top Cover Plate (H) does not fit over Glass Spacers (J), peel out the rubber inserts from the bottom of the light body (B).

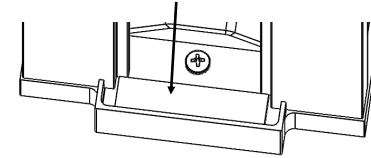

**Step 10:** If the pendant settles with a twist in the cables, unscrew the Cable Gripper Cap (F1) and use a 5/16" or adjustable wrench to gently turn the Gripper Bodies (F2) counterclockwise as shown in the image below. **Turn each gripper the same number of turns.** Once the adjustment has been made, allow the pendant to settle until it is no longer moving. Continue to make adjustments as needed until the pendant naturally settles in the desired orientation. If the light body settles too far in the opposite direction or is no longer level, remove the cables from the gripper bodies and restart step 10.

**Step 11:** Repeat steps 5-10 for each pendant light body.

