

## About Hammerton Studio

---

### HAMMERTON STUDIO

When we introduced the Hammerton Studio brand in 2014, we saw an enormous opportunity to raise the bar in decorative lighting. In design, we wanted to lead rather than follow. In construction, we wanted to showcase Hammerton's renowned reverence for time-honored artisan craftsmanship and authentic materials. In performance, we wanted to provide highly reliable solutions that far exceeded industry norms for aesthetics, function, and quality. Based on the brand's dramatic growth and customer feedback, it's clear we are on the right track.

### EXTRAORDINARY DESIGN VALUE IN ARTISAN GLASS & METALWORK

Hammerton began in 1995 as a blacksmith shop, but we've come a long way since then. Today we employ a world class team of metal artisans who are disciplined in a broad range of fabrication techniques and processes. We've also added in-house capabilities in blown, cast and kiln-fused glass, and today Hammerton operates one of the largest artisan glass production facilities in the U.S. With deep design and fabrication expertise at the intersection of glass and metalwork, we're laying the foundation for a new era of lighting innovation.

### THE HAMMERTON HERITAGE

Our Hammerton Studio brand stands on the shoulders of more than a quarter century of experience pushing the boundaries of innovative custom lighting design. Each Hammerton Studio collection has been inspired by custom work our company has brought to life in collaboration with leading interior design professionals over the years. Built to your specifications, every fixture reflects the uncompromising design and attention to detail that is distinctly Hammerton.

### A REPUTATION REFLECTED BY OUR CLIENTS

Hammerton fixtures are as extraordinary as the clients who purchase them, including Forbes 400 members, Fortune 500 leaders, award-winning entertainers, fashion and interior designers, sports legends, and leading luxury hospitality brands.

Hammerton Inc.  
217 Wright Brothers Drive  
Salt Lake City, UT 84116

801-973-8095 EXT: 4  
[www.hammerton.com](http://www.hammerton.com)

## Warranty

---

Please visit:  
<https://studio.hammerton.com/lifetime-limited-warranty/>  
to view the Hammerton Studio Warranty Policy

# HAMMERTONSTUDIO™

## Assembly Instructions

### Tessera Vanity

*Image below is a representation of applicable product collection*

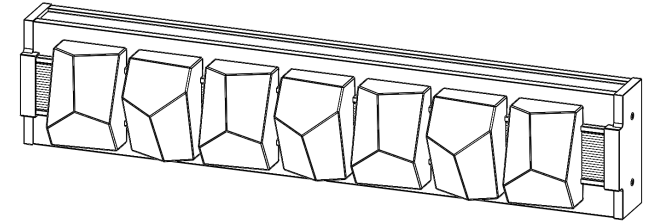

VLB0100

**WARNING:** FAILURE TO INSTALL THIS FIXTURE PROPERLY MAY RESULT IN SERIOUS PERSONAL INJURY OR DEATH AND PROPERTY DAMAGE.

It is recommended that this product be installed by a licensed electrician.

41-001-00295  
Rev 3

## Included Components

- A. Hardware Packet, with Instructions
- B. Vanity Light Body
- C. Inner Cover Plate
- D. End Cover Plate (QTY: 2)
- E. Cast Glass
- F. Glass Spacers

## Required Tools

- 1. Phillips screw driver (not provided)
- 2. Wire cutters/strippers (not provided)
- 3. Measuring tape (not provided)
- 4. Level (not provided)

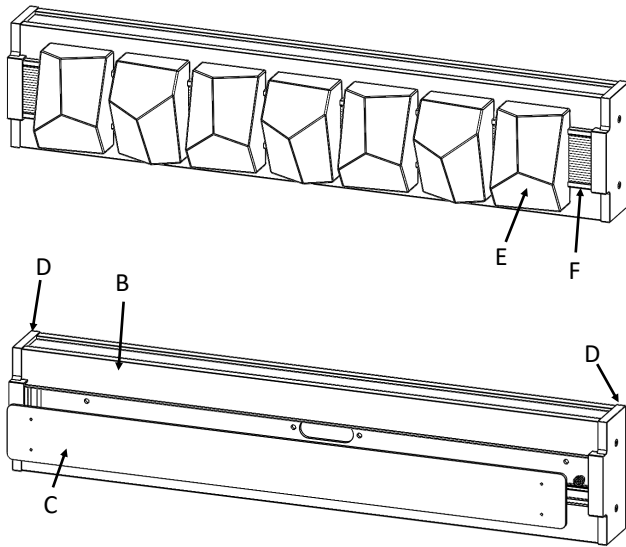

Example Fixture Shown: VLB0100-24

## Assembly Instructions

**Step 1:** Gently remove cover plate (C) from light body (B) by hand. The cover plate (C) is attached with magnets, so no tools are required.

**Step 2:** Mount the light body, following the instructions included in the hardware packet. For 36" fixtures, use the included hardware to structurally mount the light fixture after mounting to the J-Box.

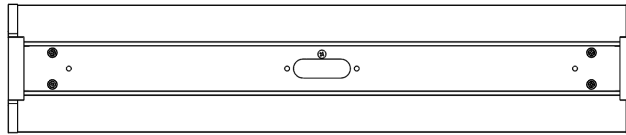

**Step 3:** Make electrical connections from the building to the light body using the wire nuts provided, connecting the ground wire to the ground, the white wire to neutral, and the black wire to hot.

**Step 4:** Replace the cover plate removed previously, lining up the magnets so the cover plate stays in place securely.

**Step 5:** Use a screwdriver to remove one of the end cover plates (D) on the light body (B). Install Glass Spacers (F) and Cast Glass (E) by sliding them into the interlocking grooves in the light body. Install the larger spacers at the ends of the fixture, and use the smaller spacers between each glass piece. Alternate direction of cast glass pieces as desired. Replace the end cover plate (D) using the two screws removed previously. If installing a Tetro option vanity, be sure to install the smaller pieces of glass first, then alternate with larger pieces.

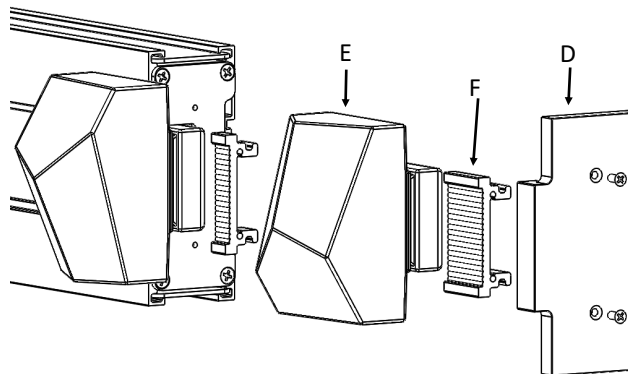

**Step 9:** If endplate does not fit over Glass Spacers (F), peel out the rubber insert from one or both of the end cover plates.

