

About Hammerton Studio

HAMMERTON STUDIO

When we introduced the Hammerton Studio brand in 2014, we saw an enormous opportunity to raise the bar in decorative lighting. In design, we wanted to lead rather than follow. In construction, we wanted to showcase Hammerton's renowned reverence for time-honored artisan craftsmanship and authentic materials. In performance, we wanted to provide highly reliable solutions that far exceeded industry norms for aesthetics, function, and quality. Based on the brand's dramatic growth and customer feedback, it's clear we are on the right track.

EXTRAORDINARY DESIGN VALUE IN ARTISAN GLASS & METALWORK

Hammerton began in 1995 as a blacksmith shop, but we've come a long way since then. Today we employ a world class team of metal artisans who are disciplined in a broad range of fabrication techniques and processes. We've also added in-house capabilities in blown, cast and kiln-fused glass, and today Hammerton operates one of the largest artisan glass production facilities in the U.S. With deep design and fabrication expertise at the intersection of glass and metalwork, we're laying the foundation for a new era of lighting innovation.

THE HAMMERTON HERITAGE

Our Hammerton Studio brand stands on the shoulders of more than a quarter century of experience pushing the boundaries of innovative custom lighting design. Each Hammerton Studio collection has been inspired by custom work our company has brought to life in collaboration with leading interior design professionals over the years. Built to your specifications, every fixture reflects the uncompromising design and attention to detail that is distinctly Hammerton.

A REPUTATION REFLECTED BY OUR CLIENTS

Hammerton fixtures are as extraordinary as the clients who purchase them, including Forbes 400 members, Fortune 500 leaders, award-winning entertainers, fashion and interior designers, sports legends, and leading luxury hospitality brands.

Hammerton Inc.
217 Wright Brothers Drive
Salt Lake City, UT 84116

801-973-8095 EXT: 4
www.hammerton.com

Warranty

Please visit:
<https://studio.hammerton.com/lifetime-limited-warranty/>
to view the Hammerton Studio Warranty Policy

HAMMERTONSTUDIO™

Assembly Instructions

SNB00XX-03, SNB00XX-06 (chain options)

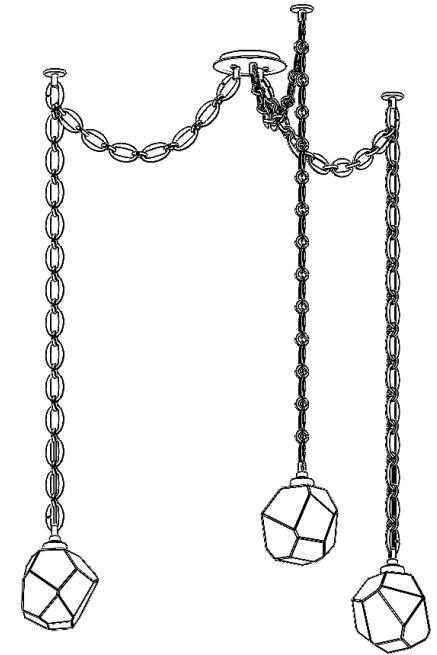

Example: SNB0039-03
Gem 3PC Chain Swag Multi-Pendant

**WARNING: FAILURE TO INSTALL THIS
FIXTURE PROPERLY MAY RESULT IN
SERIOUS PERSONAL INJURY OR DEATH
AND PROPERTY DAMAGE.**

It is recommended that this product be installed
by a licensed electrician who is familiar with
proper LED installation and electrical loads.

41-001-00309
Rev 1

Included Components

- A. Hardware Packet, with Instructions
- B. Canopy
 - B1. Chain Grips
 - B2. Cylinder Knobs
- C. Pendants
 - C1. Light Body
 - C2. Chain Grip
 - C3. Blown Glass
- D. Chain swag hooks
 - D1. E-Z Toggle Bolts
 - D2. Swag Mini-Canopies
 - D3. Threaded Washer
 - D4. Flathead Toggle Screw
 - D5. Chain Grip
- E. Chain (unassembled)
 - E1. Ring Chain Links
 - E2. Flat Chain Links
 - E3. Open Flat Chain Links

Required Tools

1. Allen Key (provided for Ledgestone)
2. Philips screw driver (not provided)
3. Wire cutters/strippers (not provided)
4. Measuring tape (not provided)

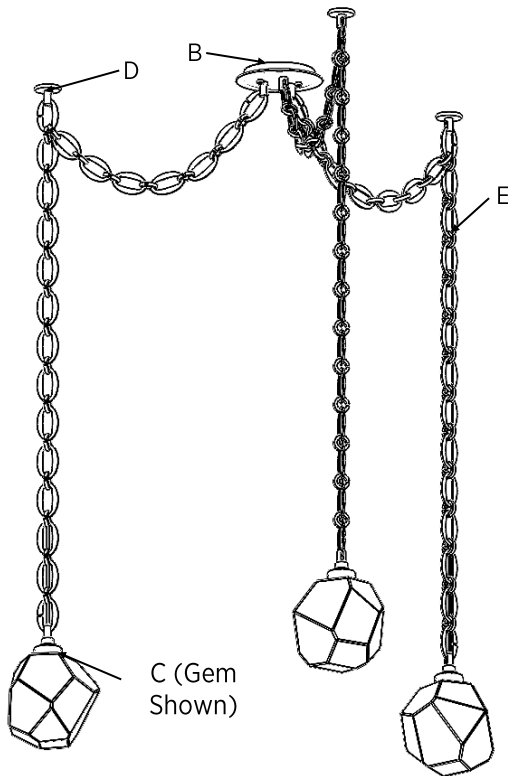

Assembly Instructions

Step 1: TURN OFF POWER TO JUNCTION BOX TO BE USED FOR INSTALLATION.

WARNING:

Failure to use the LED driver to power the fixture will permanently damage your product making it unusable

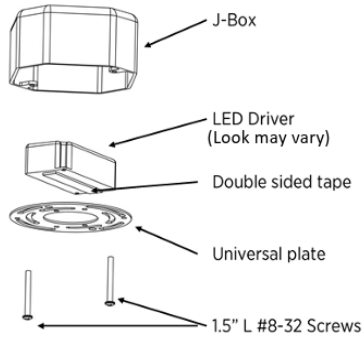

Step 2: Make 120 VAC connections from the power source to the driver, **Black to Live** and **White to Neutral**. Place driver inside of J-Box, leaving the driver output (Red and Black) wires accessible. Affix the universal plate to the J-Box using the 1.5" L #8-32 screws provided in the mounting pack.

Step 3: Attach canopy (B) using the canopy carabiner to the universal to temporarily hang canopy as shown below

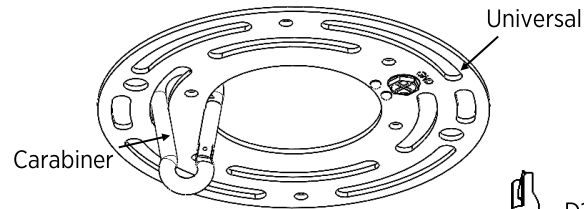

Step 4: Using the E-Z Toggle bolts (D1) (see E-Z Toggle Instructions on the next page) included in the Hardware pack (A), install E-Z Toggle bolts (D1) radially around the Canopy (B) using a measuring tape to achieve the desired distance. **Note:** Toggle bolt location determines pendant location.

Step 5: Use the provided E-Z Toggle Screws (D4) to attach the Swag Mini-Canopies (D2) and Threaded Washers (D3) to the Toggle Bolts (D1). Once tightened, gently bend open one of the provided Open Chain Links (E3) and slide inside of the provided Chain Grip (D5), then bend the open chain link straight. Screw the Chain Grip (D5) onto the Threaded Washer (D3).

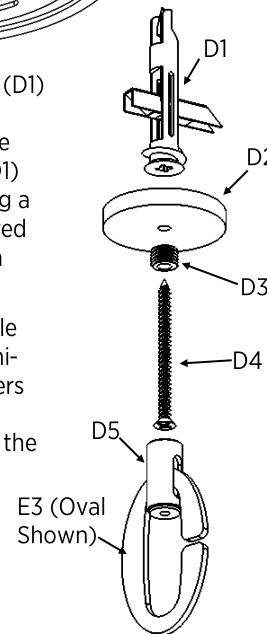

Figure 1

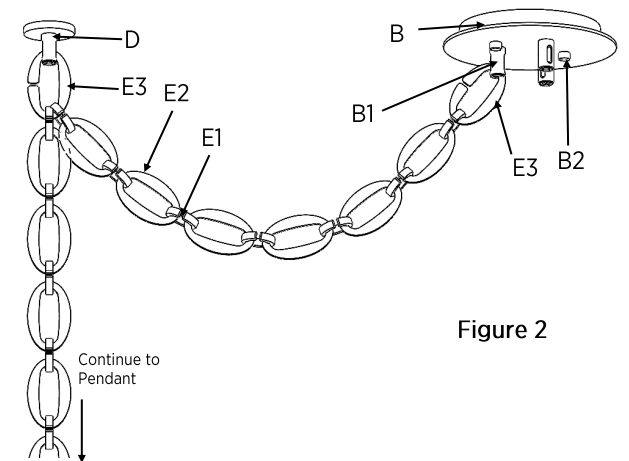

Figure 2

Step 6: Starting from the Open Chain Link (E3) attached to the mini canopy (D2) Assemble the chain by interlocking alternating Flat Chain Links (E2) and Ring Chain Links (E1) (See Figure 2 for example) until desired overall height for pendant is achieved. Then, starting from the Open Chain Link (E3) attached to the mini canopy (D2) once more, assemble the chain towards the main canopy until the distance between the main canopy and the mini canopy is covered.

Step 7: Let both the pendant chain, and the chain run to the main canopy hang only from the mini canopies, so that they are both pointing directly towards the ground.

Step 8: Attach Pendant Light Body (C1) to the pendant chain using the pre-attached chain link (E3).

Step 9: Thread the pendant wires through the chain, weaving it back and forth through the Flat Chain Link openings up the pendant chain and then down the chain run for the main canopy.

Step 10: Once all pendants are installed, attach the pendants (one at a time) to the faceplate by first threading the pendant wire through the hole in the top of the chain grip (B1), then using the provided Flat Open Chain Links (E3) to attach the chain to the canopy by gently bending them open then sliding them through the slot in the chain grips (B1). Bend them straight once installed.

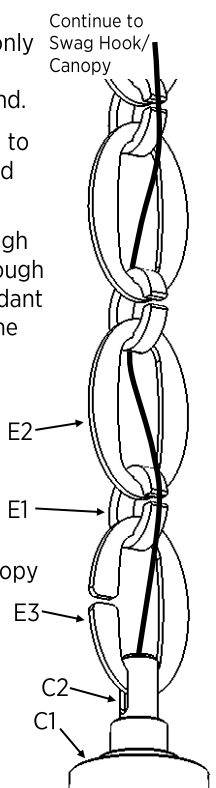

NOTE: Pendant wires have a smooth wire (+) and a rough wire (-) (Figure 3) (wires are marked Red (+) and Black (-) on ends to improve visibility)

Step 11: Follow the 3 Pendant or 6 Pendant wiring instructions according to fixture configuration

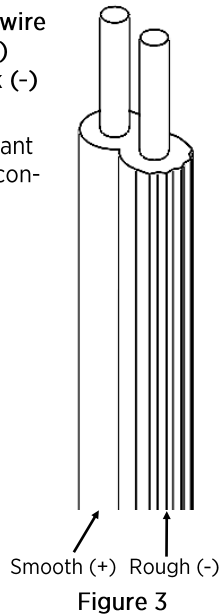

3 Pendant Configuration

Step 12: Make wire connections from the Pendant assemblies to the LED Driver according to the diagram shown below. **Note:** Pendant order does not matter. Pick any Pendant to be Pendant 1, 2, 3 Etc.

- 1) Connect the **ROUGH** wire of Pendant 1 to the **BLACK** wire from the driver.
- 2) Connect the **SMOOTH** wire of Pendant 1 to the **ROUGH** wire of Pendant 2
- 3) Connect the **SMOOTH** wire of Pendant 2 to the **ROUGH** wire of Pendant 3
- 4) Connect the **SMOOTH** wire of Pendant 3 to the **RED** wire from the driver.

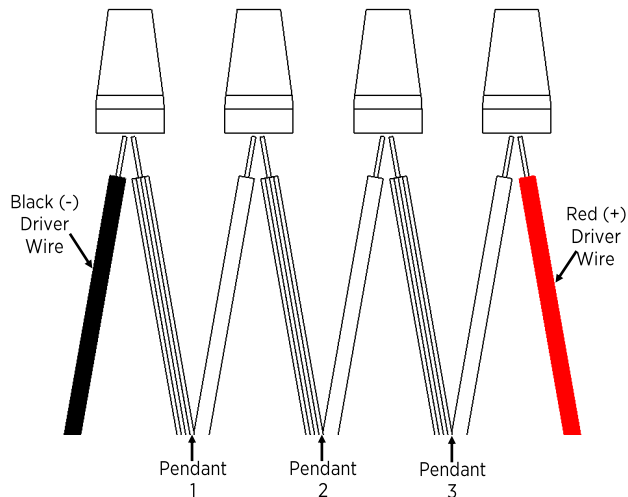

6 Pendant Configuration

Step 12: Make wire connections from the Pendant assemblies to the LED Driver according to the diagram shown below. **Note:** Pendant order does not matter. Pick any Pendant to be Pendant 1, 2, 3 Etc.

- 1) Connect the **SMOOTH** wire of both Pendant 1 and 4 to the **RED** wire from the driver.
- 2) Connect the **ROUGH** wire of Pendant 1 to the **SMOOTH** wire of Pendant 2
- 3) Connect the **ROUGH** wire of Pendant 2 to the **SMOOTH** wire of Pendant 3
- 4) Connect the **ROUGH** wire of Pendant 4 to the **SMOOTH** wire of Pendant 5
- 5) Connect the **ROUGH** wire of Pendant 5 to the **SMOOTH** wire of Pendant 6
- 6) Connect the **ROUGH** wire of both Pendant 3 and 6 to the **BLACK** wire from the driver.

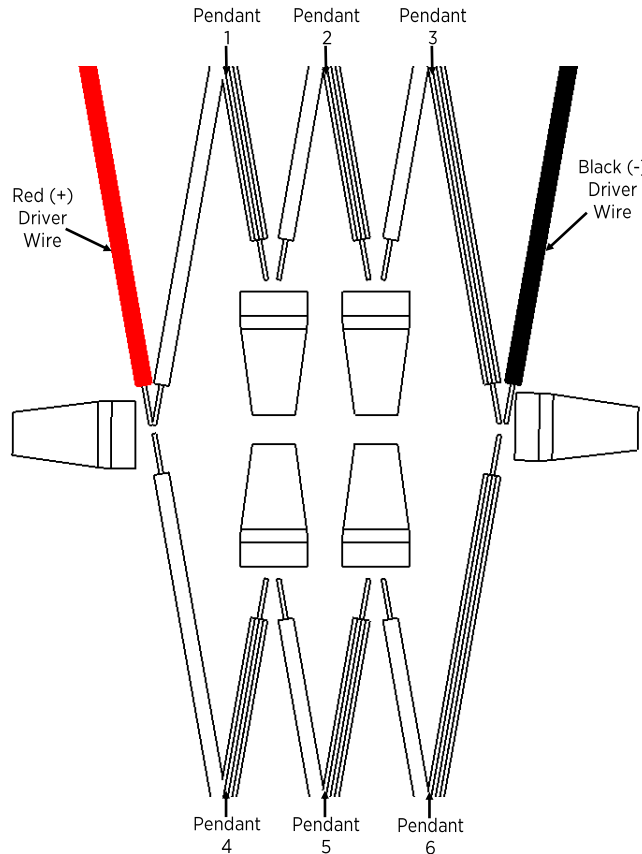

Step 13: Follow the provided **Mounting Instructions** to mount canopy to the installed universal.

Step 14: Install Glass to the pendant body according to the instructions on the following page.

Prior to installing glass ensure all Chain Links are properly secured through each swag hook so the glass is being supported by the swag hook and not the canopy. Solely supporting by the canopy may overload the J-Box mount resulting in damage.

If Nebula Pendant: Screw inner glass into socket. Un-Screw Glass Retention nut. Raise the Top Glass Retention Cap up the stem. Slide Glass Shade over inner glass, tilt to the side of the glass allowing the Bottom Glass Retention to slip inside the Glass Shade, slide the rest of the Bottom Glass Retention the rest of the way into the Glass Shade, Allow the Glass to sit on the top of the lips of the Bottom Glass Retention. and Secure Retention Nut. **(NOTE: Tighten till Snug. DO NOT Overtighten!)**

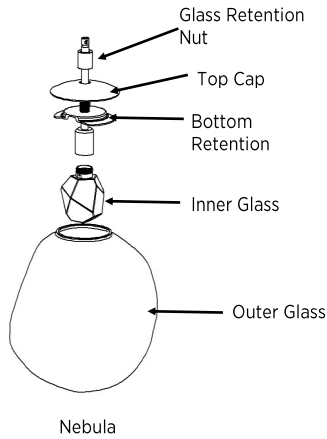

Gem, Rock Crystal, or Aalto Pendant: Use #4-40 flat head screws provided to attach glass to pendant housing.

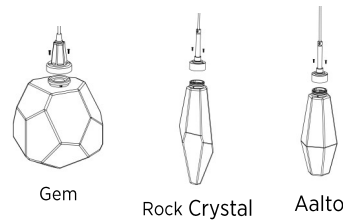

If Mesa, Gaia, or Vessel: Screw glass element into threaded cup.

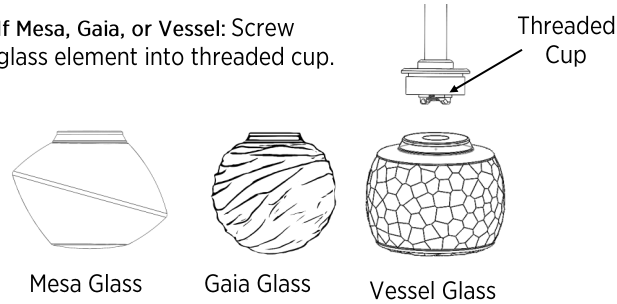

E-Z Toggle™ Instructions

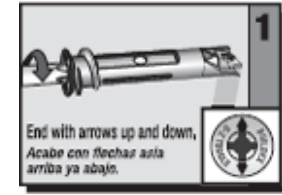

Turn E-Z Toggle into drywall until seated flush. Arrows on head indicate direction toggle clamp will open. End with arrows up and down.

Ledgestone Pendant: Use #8-32 nylon tip set screws to retain blown glass.



Ledgestone

Parallel Glass Pendant: Unscrew cylinder knobs, then place glass panel inside of housing and thread cylinder knobs back in, ensuring that the threads of the knob pass through the hole in the glass panel.

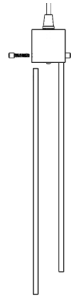

Parallel

If Blossom Pendant: Screw glass element into threaded pendant housing.



Blossom

If Raindrop Glass Pendant: Place frosted diffuser in glass mount, Then screw the glass assembly onto the threaded LED mount inside of top cap.

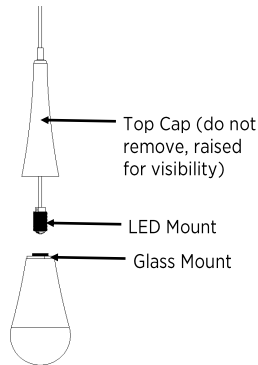

Raindrop

If Pebble: Glass comes pre-attached to fixture.

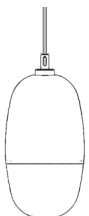

Pebble

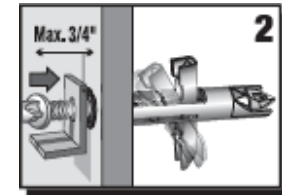

Place fixture over E-Z Toggle. Push screw into E-Z Toggle to engage clamp

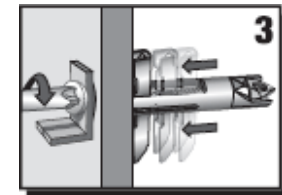

Turn screw until it stops. Toggle clamp tightens against drywall as screw is turned.