

## About Hammerton Studio

---

### HAMMERTON STUDIO

When we introduced the Hammerton Studio brand in 2014, we saw an enormous opportunity to raise the bar in decorative lighting. In design, we wanted to lead rather than follow. In construction, we wanted to showcase Hammerton's renowned reverence for time-honored artisan craftsmanship and authentic materials. In performance, we wanted to provide highly reliable solutions that far exceeded industry norms for aesthetics, function, and quality. Based on the brand's dramatic growth and customer feedback, it's clear we are on the right track.

### EXTRAORDINARY DESIGN VALUE IN ARTISAN GLASS & METALWORK

Hammerton began in 1995 as a blacksmith shop, but we've come a long way since then. Today we employ a world class team of metal artisans who are disciplined in a broad range of fabrication techniques and processes. We've also added in-house capabilities in blown, cast and kiln-fused glass, and today Hammerton operates one of the largest artisan glass production facilities in the U.S. With deep design and fabrication expertise at the intersection of glass and metalwork, we're laying the foundation for a new era of lighting innovation.

### THE HAMMERTON HERITAGE

Our Hammerton Studio brand stands on the shoulders of more than a quarter century of experience pushing the boundaries of innovative custom lighting design. Each Hammerton Studio collection has been inspired by custom work our company has brought to life in collaboration with leading interior design professionals over the years. Built to your specifications, every fixture reflects the uncompromising design and attention to detail that is distinctly Hammerton.

### A REPUTATION REFLECTED BY OUR CLIENTS

Hammerton fixtures are as extraordinary as the clients who purchase them, including Forbes 400 members, Fortune 500 leaders, award-winning entertainers, fashion and interior designers, sports legends, and leading luxury hospitality brands.

Hammerton Inc.  
217 Wright Brothers Drive  
Salt Lake City, UT 84116

801-973-8095 EXT: 4  
[www.hammerton.com](http://www.hammerton.com)

## Warranty

---

Please visit:  
<https://studio.hammerton.com/lifetime-limited-warranty/>  
to view the Hammerton Studio Warranty Policy

# HAMMERTONSTUDIO™

## Assembly Instructions

LNB00XX-01

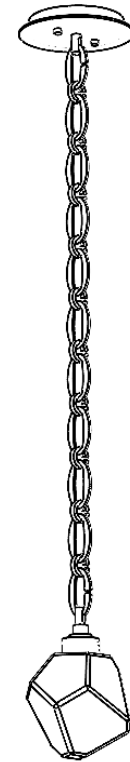

Example: LNB0039  
Gem Pendant

**WARNING: FAILURE TO INSTALL THIS  
FIXTURE PROPERLY MAY RESULT IN  
SERIOUS PERSONAL INJURY OR DEATH  
AND PROPERTY DAMAGE.**

It is recommended that this product be installed  
by a licensed electrician who is familiar with  
proper LED installation and electrical loads.

41-001-00310  
Rev 1

## Included Components

- A. Hardware Packet, with Instructions
- B. Canopy
  - B1. Canopy Faceplate
  - B2. Chain Grips
  - B3. Flat Knob
- C. Pendant
  - C1. Light Body
  - C2. Chain Grip
  - C3. Blown Glass
- D. Chain swag hooks
  - D1. E-Z Toggle Bolts
  - D2. Swag Mini-Canopies
  - D3. Threaded Washer
  - D4. Flathead Toggle Screw
  - D5. Chain Grip
- E. Chain (unassembled)
  - E1. Ring Chain Links
  - E2. Flat Chain Links
  - E3. Open Flat Chain Links

## Required Tools

1. Allen Key (provided for Ledgestone)
2. Philips screw driver (not provided)
3. Wire cutters/strippers (not provided)
4. Measuring tape (not provided)

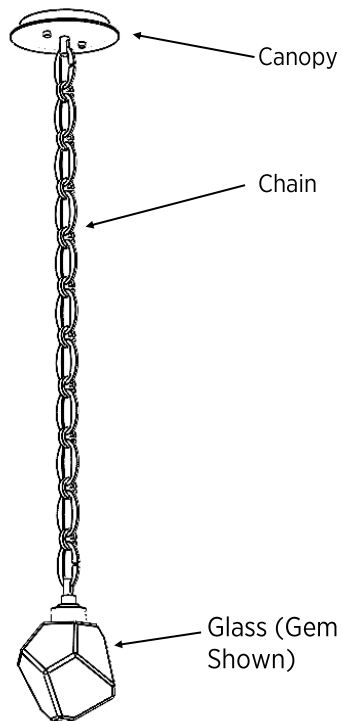

## Assembly Instructions

**Step 1: TURN OFF POWER TO JUNCTION BOX TO BE USED FOR INSTALLATION.**

### WARNING:

Failure to use the LED driver to power your pendant will permanently damage your product making it unusable

**Step 2: Mount LED driver into J-Box.** Make 120 VAC connections from the power source to the driver using the Black and White wires. Place driver inside of J-Box, leaving the driver output wires accessible. Affix the universal plate to the J-Box using the 1.5" L #8-32 screws provided in the mounting pack.

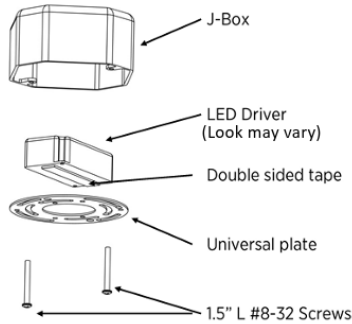

**Step 3: Mount the canopy to the ceiling using the provided Mounting Instructions.** Then gently bend open one of the provided Open Chain Links (E3) and slide inside of the provided Chain Grip (D5), but don't bend the open link straight yet.

**Step 4: Starting from the open chain link attached to the canopy, assemble the chain by interlocking alternating Flat Chain Links (E2) and Ring Chain Links (E1) until desired overall height for pendant is achieved.**

**Step 5: Attach pendant light body (C1) to the pendant chain using the pre-attached chain link (E3).**

**Step 6: Thread the pendant wires through the chain, weaving it back and forth through the Flat Chain Link openings up the pendant chain until you reach the canopy.**

**Step 7: Remove the canopy and carefully hold it to the side. Thread the pendant wire through the hole in the top of the chain grip (B2). If it is difficult to fit the wires past the Open Chain Link, remove it and replace it after threading the wire through the Chain Grip.**

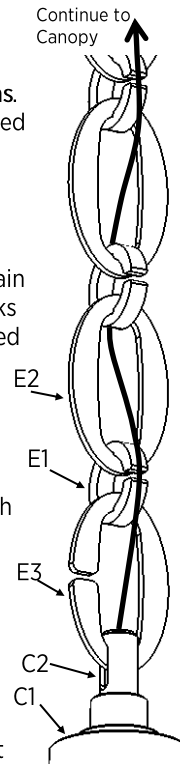

**NOTE: Pendant wires are marked red and black on ends of wires, do not cut wires until you are ready to install them.** (in the event that the identifying colors are cut off the wire, the wire that is subtly rough on one edge corresponds to black and the smooth wire corresponds to red)

**Step 8: Peel back the red wire of pendant (pendant wire splits into 2) clip and strip to length, and connect it to the positive (RED) output of the driver using the pre-attached WAGO Lever-Nuts. Then clip the black wire to length and attached to the negative (BLACK) output of the driver.**

**Step 9: Reinstall the canopy.**

**Step 10: Install Glass to the pendant body according to the instructions on the next page.**

**Gem, Rock Crystal, or Aalto Pendant:**

Use #4-40 flat head screws provided to attach glass to pendant housing.

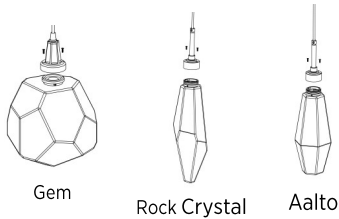

**Ledgestone Pendant:**

Use #8-32 nylon tip set screws to retain blown glass.

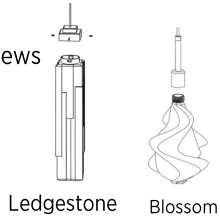

**If Blossom Pendant:**

Screw glass element into threaded pendant housing.

**If Nebula Pendant:**

Screw inner glass into socket. Unscrew Glass Retention nut. Raise the Top Glass Retention Cap up the stem. Slide Glass Shade over inner glass, tilt to the side of the glass allowing the Bottom Glass Retention to slip inside the Glass Shade, slide the rest of the Bottom Glass Retention the rest of the way into the Glass Shade, Allow the Glass to sit on the top of the lips of the Bottom Glass Retention. and Secure Retention Nut. (NOTE: Tighten till Snug. DO NOT Overtighten!)

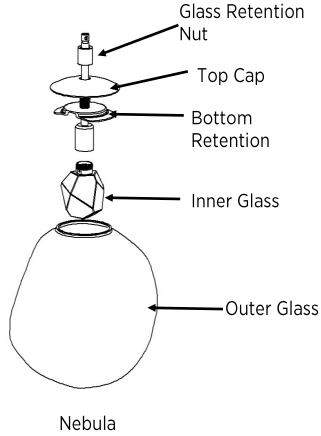

**Parallel Glass Pendant:**

Install glass panels by unscrewing the cylinder knobs until glass can be slid into housing.

Note that the cylinder knobs do not have to be fully removed from the fixture to install glass panels. Tighten the cylinder knobs, ensuring that the all thread passes through the glass panels.

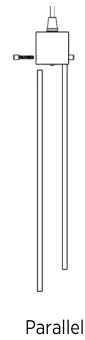

**If Raindrop Glass Pendant:**

Place frosted diffuser in glass mount, Then screw the glass assembly onto the threaded LED mount inside of top cap.

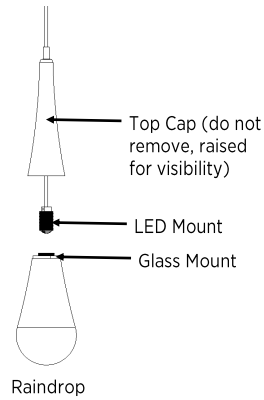

If Mesa, Gaia, or Vessel: Screw glass element into threaded cup.

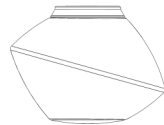
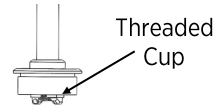

Mesa Glass



Gaia Glass



Vessel Glass

If Pebble: Glass comes pre-attached to fixture.

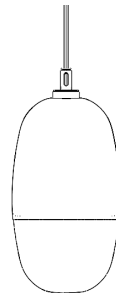

Pebble