

Included Components

- A. Hardware Packet Y
- B. Handblown Glass (QTY:6-8)
- C. Stone or Metal Shade (QTY:6-8)
- D. Canopy
- E. Adjustable Threaded Rod (Instructions included)
- F. Driver
- G. Loctite (Stone Configuration Only)

Note: Branch Shown in Example Images.

Vine is the same operations in different orientation

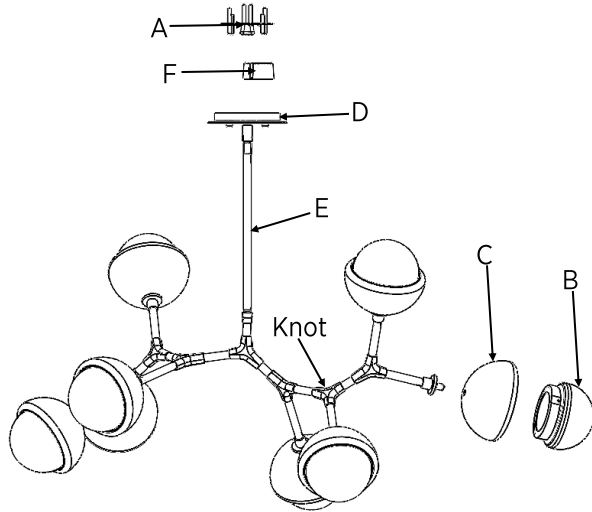

PLB0093-BB Example

Required Tools

1. Philips screw driver (not included)
2. Wire cutters/strippers (not provided)
3. Measuring tape (not provided)
4. 1/16 Allen Key (provided)

Assembly Instructions

Step 1: Using the provided **Threaded Rod Instructions**, assemble the light with the desired OAH. Loctite must be used on the threaded rods before final install.

Step 2: Run fixture wire through the assembled threaded rod and screw rod into the top of the fixture, then run fixture wires through canopy hang straight and thread canopy onto threaded rod.

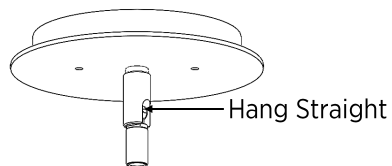

Step 3: Install LED driver in J-Box. Dry fit driver and universal mounting plate before securing driver with double sided tape.

Step 4: Make wire connections from driver to source power, **Black to Black and White to White.**

Step 5: Mount the fixture to J-Box following the provided **Y-Mounting Instructions.**

Step 6: Connect the direct current (DC) wires from the fixture to the driver. (**Black to Black and Red to Red**)
NOTE: RED and BLACK wires are for DC power only.

Orienting Knots

Position of branch knots may be adjusted *Before Glass and Stone is Installed* with the included 1/16 Allen key. **DO NOT ROTATE 180 DEGREES PAST ORIGINAL POSITION. ENSURE SET SCREW IS FLUSH WITH KNUCKLE AND TIGHTLY FIXED INTO THREADS.**

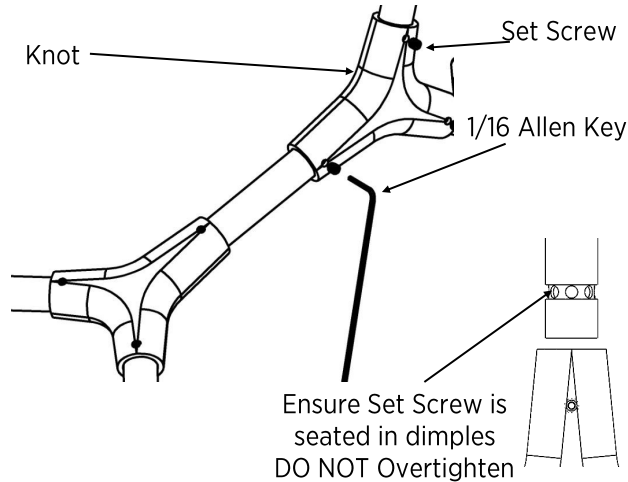

Step 7: Skip steps 8-11 for Metal Shade configuration.

Step 8: Remove LED heatsinks from retention cups by unscrewing the pan-head Phillips screws. (set screws aside for later)

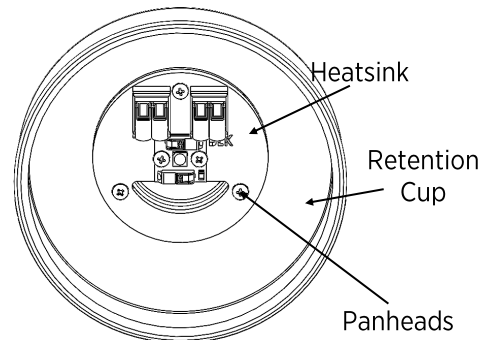

Step 9: Apply Loctite to the shown IPS threads. Run Stone Shade over wire and IPS. Run retention cup over wire and thread onto IPS until tightened firmly.

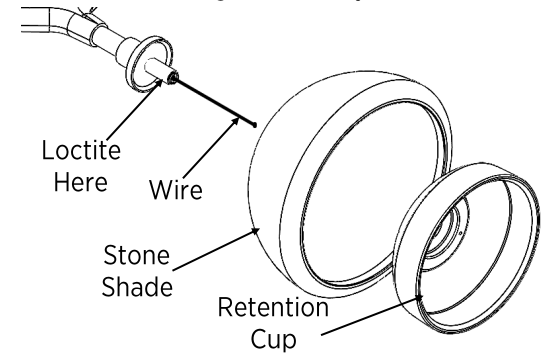

Step 10: Run wire through the half circle on the LED Heatsink and secure heatsink to retention cup using the pan-head Phillips screws you set aside earlier.

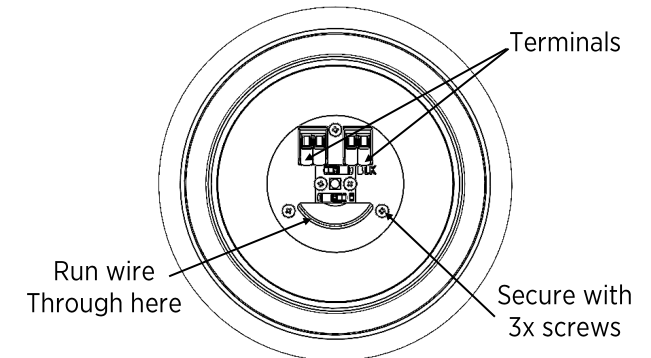

Step 11: Flip up the leftmost and rightmost orange terminals shown above. Strip wires and run the **black wire** to the side labelled **BLK** and the **red wire** to the unlabeled side, and flip terminals closed.

Step 12: Install glass by screwing the threaded collar on the glass into the threaded retention cup.
NOTE: Install glass one at a time, ensuring fixture remains balanced.

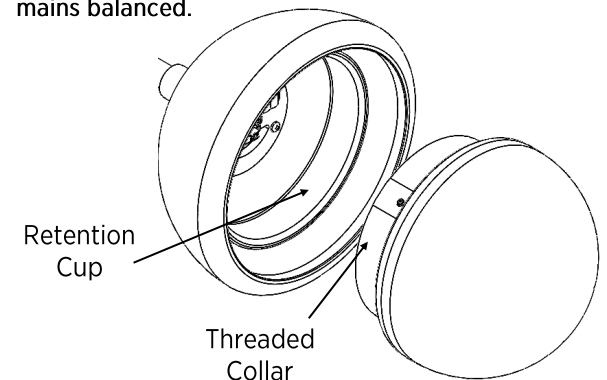

About Hammerton Studio

HAMMERTON STUDIO

When we introduced the Hammerton Studio brand in 2014, we saw an enormous opportunity to raise the bar in decorative lighting. In design, we wanted to lead rather than follow. In construction, we wanted to showcase Hammerton's renowned reverence for time-honored artisan craftsmanship and authentic materials. In performance, we wanted to provide highly reliable solutions that far exceeded industry norms for aesthetics, function, and quality. Based on the brand's dramatic growth and customer feedback, it's clear we are on the right track.

EXTRAORDINARY DESIGN VALUE IN ARTISAN GLASS & METALWORK

Hammerton began in 1995 as a blacksmith shop, but we've come a long way since then. Today we employ a world class team of metal artisans who are disciplined in a broad range of fabrication techniques and processes. We've also added in-house capabilities in blown, cast and kiln-fused glass, and today Hammerton operates one of the largest artisan glass production facilities in the U.S. With deep design and fabrication expertise at the intersection of glass and metalwork, we're laying the foundation for a new era of lighting innovation.

THE HAMMERTON HERITAGE

Our Hammerton Studio brand stands on the shoulders of more than a quarter century of experience pushing the boundaries of innovative custom lighting design. Each Hammerton Studio collection has been inspired by custom work our company has brought to life in collaboration with leading interior design professionals over the years. Built to your specifications, every fixture reflects the uncompromising design and attention to detail that is distinctly Hammerton.

A REPUTATION REFLECTED BY OUR CLIENTS

Hammerton fixtures are as extraordinary as the clients who purchase them, including Forbes 400 members, Fortune 500 leaders, award-winning entertainers, fashion and interior designers, sports legends, and leading luxury hospitality brands.

Hammerton Inc.
217 Wright Brothers Drive
Salt Lake City, UT 84116

801-973-8095 EXT: 4
www.hammerton.com

Warranty

Please visit:
<https://studio.hammerton.com/lifetime-limited-warranty/>
to view the Hammerton Studio Warranty Policy

HAMMERTONSTUDIO™

Assembly Instructions Cabochon Modern Branch/ Modern Vine

PLB0093-BA, PLB0093-BB, CHB0093-VA,
CHB0093-VB

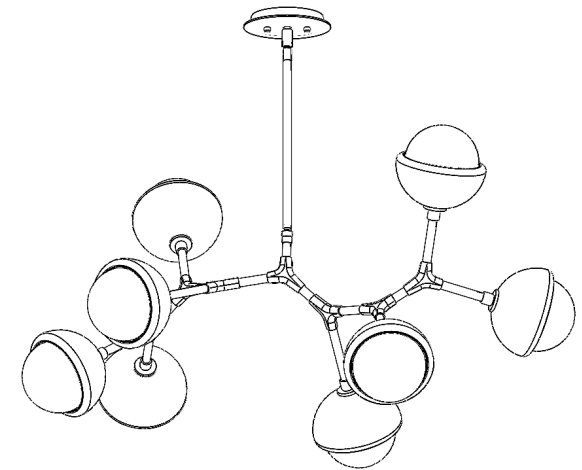

PLB0093-BB

**WARNING: FAILURE TO INSTALL THIS
FIXTURE PROPERLY MAY RESULT IN
SERIOUS PERSONAL INJURY OR DEATH
AND PROPERTY DAMAGE.**

It is recommended that this product be installed
by a licensed electrician.

41-001-00312
Rev 1