

About Hammerton Studio

HAMMERTON STUDIO

In 2013, the Hammerton Studio brand was created to offer artisan-crafted, contemporary design solutions that are both versatile and accessible. Hammerton Studio fixtures add contemporary distinction to entries, great rooms and master suites, yet are cost-effective enough to use throughout any residential or commercial projects. Like all Hammerton fixtures, they are designed and fabricated in Salt Lake City, Utah using domestically sourced materials.

POWERFUL DESIGN

Since 1992, Hammerton has been known for extraordinary decorative lighting that is boldly designed, expertly rendered, perfectly proportioned and exquisitely detailed. Each fixture exudes a design aesthetic that is timeless and enduring, yet remarkably relevant.

UNCOMPROMISING CRAFTSMANSHIP

In addition to their exceptional metalworking and finishing expertise, Hammerton artisans share an aesthetic eye and a sculptural talent that define the difference between ordinary and extraordinary craftsmanship. Every fixture demonstrates its artisan's ability to elevate craft to an art form.

UNIQUE MATERIALS

Our heritage is in metal fabrication, but our passion is design. As a result—and unlike most of our peers—we work in a broad palette of materials: steel and aluminum, blown, kiln-fired and lampworked glass, acrylics, mica, stone, rawhide, woods and much more. Seamless integration of these capabilities is the "secret sauce" that drives our industry leadership as the premier U.S. based custom lighting manufacturer.

A REPUTATION REFLECTED BY OUR CLIENTS

Hammerton fixtures are as extraordinary as the clients who purchase them, including Forbes 400 members, Fortune 500 leaders, award-winning entertainers, fashion and interior designers, sports legends, and leading luxury hospitality brands.

Hammerton
217 Wright Brothers Drive
Salt Lake City, UT
84116

801-973-8095
info@hammerton.com
www.hammerton.com

Warranty

Please visit:
<https://studio.hammerton.com/lifetime-limited-warranty/>
to view the Hammerton Studio Warranty Policy

HAMMERTONSTUDIO™

Assembly Instructions CHB0098/PLB0098

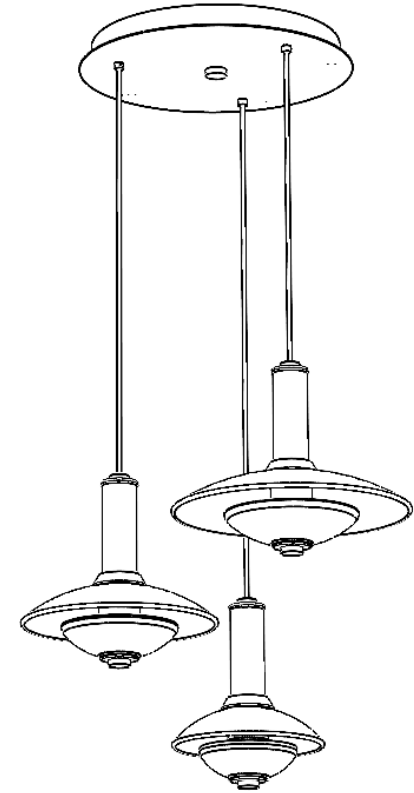

Example: CHB0098-03
Cirrus 3 PC Multi-Pendant

WARNING: FAILURE TO INSTALL THIS FIXTURE PROPERLY MAY RESULT IN SERIOUS PERSONAL INJURY OR DEATH AND PROPERTY DAMAGE.

It is recommended that this product be installed by a licensed electrician who is familiar with proper LED installation and electrical loads.

Included Components

- A. Hardware Packet, with Instructions
- B. Canopy
 - B1. Canopy Faceplate
 - B2. Driver(s)
 - B3. Terminal Block(s)
- C. Pendants
 - C1. Pendant Body
 - C2. Flat Glass
 - C3. Gasket
 - C4. Threaded Ring
 - C5. Foam Spacer
 - C6. Clear Spacer
 - C7. Middle Motif
 - C8. Cast Glass
 - C9. Bottom Motif

Required Tools

1. Philips screw driver (not provided)
2. Wire cutters/strippers (not provided)
3. Measuring tape (not provided)

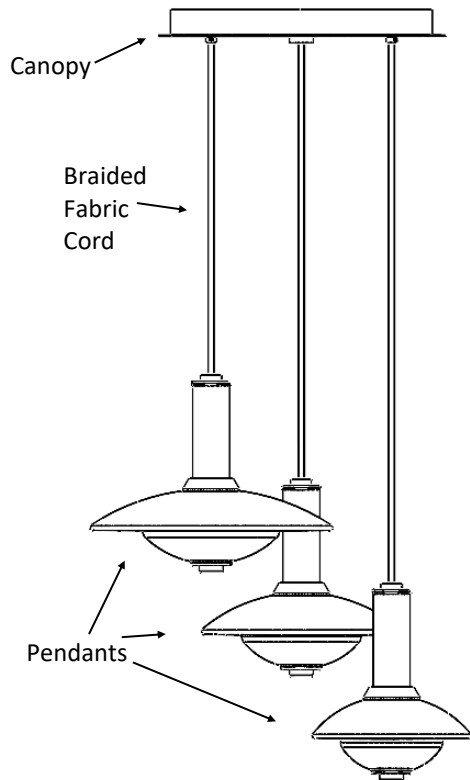

Assembly Instructions

Step 1: Make wire connections from source power to LED driver. **WHITE to WHITE** and **BLACK to BLACK**. Secure driver in J-Box with universal following provided mounting instructions. (Leave **PURPLE** and **BLACK** wires sticking out)

Step 2: Feed the braided fabric cord into the canopy until the desired amount of cord is left between the canopy and light body. Take into account that a minimum of 6" of cord will be required for connecting the wiring to the driver.

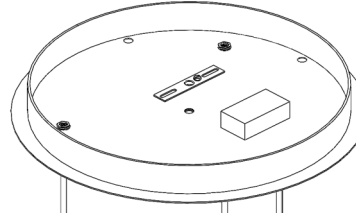

Step 3: Use a measuring tape to be sure that all of your light body is hanging the proper distance from the canopy. Tighten the cord grips using a flat blade screw driver. The cord grips are on the face of the canopy. **DO NOT OVER TIGHTEN. THIS MAY DAMAGE THE FIXTURE.**

Step 4: Connect the **PURPLE** (negative) driver wire to the **BLACK** wires from all of the pendants using wire nuts. Connect the **RED** (positive) driver wire to the **WHITE** wires from all of the pendants using wire nuts.

WARNING

DO NOT DIRECTLY CONNECT LEDs TO AC POWER. LEDs will be damaged if exposed to high voltages. The LEDs must be wired as described below to the included driver to work properly.

Step 5: Mount the canopy to the ceiling using the provided **Mounting Instructions**.

Step 5: Unscrew the Bottom Motif (C9) from the Pendant Body (C1) and remove the preinstalled Middle Motif (C7), Clear Spacer (C6), and Foam Spacer (C5). Unscrew the Threaded Ring (C4) and remove the Gasket (C3).

Step 6: Slide the Flat Glass (C2) and Gasket (C3) onto the Pendant Body (C1) and secure with the Threaded Ring (C4).

Step 7: Slide the black Foam Spacer (C5), Clear Spacer (C6), Middle Motif (C7), and Cast Glass (C8) onto the Pendant Body (C1) and secure with the Bottom Motif (C9).

NOTE

The Cast Glass and Flat Glass will be marked with a size (SM, MD, LG). Ensure that on a since pendant there is matching Cast Glass and Flat Glass sizes. LG-LG, SM-SM, etc.

