

Included Components

- Hardware Packet Y with Instructions
- Blown Glass
- Ceramic Cover
- Canopy
- Cloth Braided Cord
- Cord Grip (attached to canopy)

Required Tools

- Philips screw driver (not provided)
- Wire cutters/strippers (not provided)
- Measuring tape (not provided)

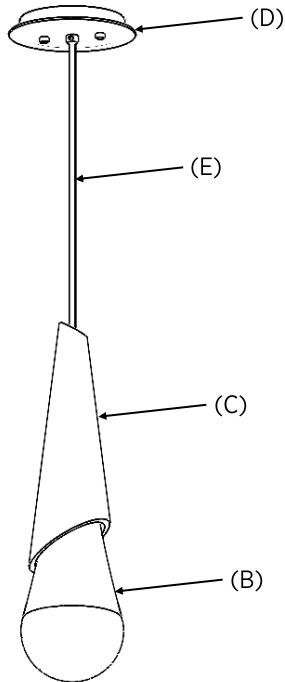
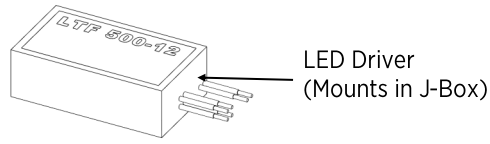

Assembly Instructions

Step 1: TURN OFF POWER TO JUNCTION BOX TO BE USED FOR INSTALLATION.

WARNING: Failure to use the LED driver to power your pendant will permanently damage your product making it unusable

Step 2: Mount LED driver into J-Box. Make 120 VAC connections from the power source to the driver using the Black and White wires. Mount the driver to the top of the universal plate provided in the mounting packet using the double sided tape pre-attached to the driver. Then affix the universal plate to the J-Box using the 1.5" L #8-32 screws provided in the mounting pack. The Blue, Red, Pink, and Purple leads should not be connected at this point.

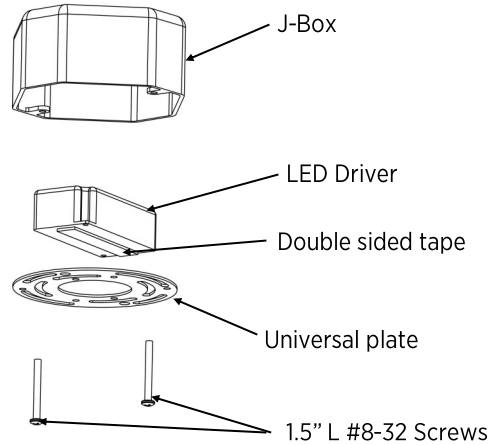

Step 3: Gently run the ceramic cover (C) all the way down the cloth braided cord (E).

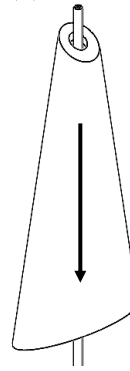

Step 4: Loosen cord grip screw and feed cloth braided cord through the cord grip on the canopy until the pendant is at the desired height. Take into account that a minimum of 6" of cord will be required for connecting the wires to the driver.

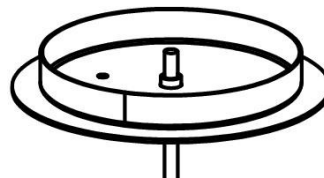

Step 5: Tighten cord grip on the canopy using a flat blade screw driver. **DO NOT OVER TIGHTEN. THIS MAY DAMAGE THE FIXTURE.**

Step 6: Make Wire Connections to the Driver. Cloth braided cord must be wired to the Driver, **Black to Blue and White to Red.**

NOTE: The **Pink** and **Purple** wires are used for optional 0-10V dimming. If not applicable, cap the wires.

Step 7: Mount the canopy to the ceiling using the provided **Mounting Instructions.**

Step 8: Attach glass to pendants using the instructions below.

Raindrop Glass Install

Step 1: Place acrylic diffuser inside glass. (**Note:** diffuser may have a white protective film. Remove this prior to install)

Step 2: Raise Ceramic Cover

Step 3: Screw glass onto threaded housing

Step 4: Lower Ceramic Cover onto glass so that the foam collar folds over the glass.

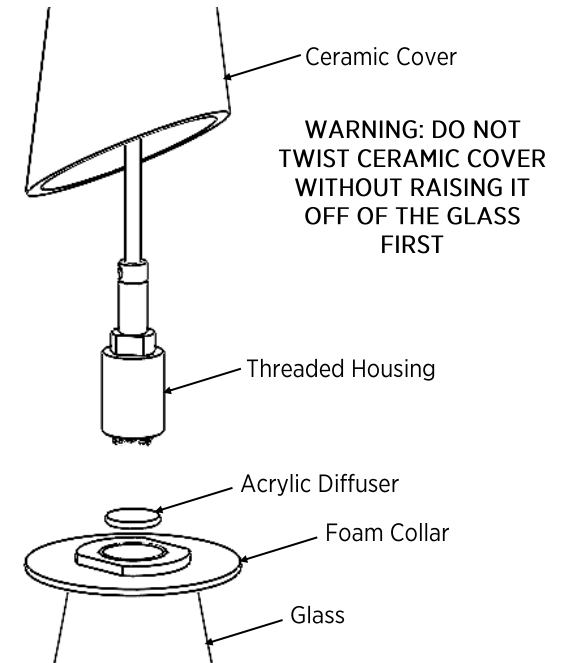

About Hammerton Studio

HAMMERTON STUDIO

When we introduced the Hammerton Studio brand in 2014, we saw an enormous opportunity to raise the bar in decorative lighting. In design, we wanted to lead rather than follow. In construction, we wanted to showcase Hammerton's renowned reverence for time-honored artisan craftsmanship and authentic materials. In performance, we wanted to provide highly reliable solutions that far exceeded industry norms for aesthetics, function, and quality. Based on the brand's dramatic growth and customer feedback, it's clear we are on the right track.

EXTRAORDINARY DESIGN VALUE IN ARTISAN GLASS & METALWORK

Hammerton began in 1995 as a blacksmith shop, but we've come a long way since then. Today we employ a world class team of metal artisans who are disciplined in a broad range of fabrication techniques and processes. We've also added in-house capabilities in blown, cast and kiln-fused glass, and today Hammerton operates one of the largest artisan glass production facilities in the U.S. With deep design and fabrication expertise at the intersection of glass and metalwork, we're laying the foundation for a new era of lighting innovation.

THE HAMMERTON HERITAGE

Our Hammerton Studio brand stands on the shoulders of more than a quarter century of experience pushing the boundaries of innovative custom lighting design. Each Hammerton Studio collection has been inspired by custom work our company has brought to life in collaboration with leading interior design professionals over the years. Built to your specifications, every fixture reflects the uncompromising design and attention to detail that is distinctly Hammerton.

A REPUTATION REFLECTED BY OUR CLIENTS

Hammerton fixtures are as extraordinary as the clients who purchase them, including Forbes 400 members, Fortune 500 leaders, award-winning entertainers, fashion and interior designers, sports legends, and leading luxury hospitality brands.

Hammerton Inc.
217 Wright Brothers Drive
Salt Lake City, UT 84116

801-973-8095
www.hammerton.com

Warranty

Please visit:
<https://studio.hammerton.com/lifetime-limited-warranty/>
to view the Hammerton Studio Warranty Policy

HAMMERTONSTUDIO™

Assembly Instructions

Ceramic Raindrop Pendant

LAB0104-01

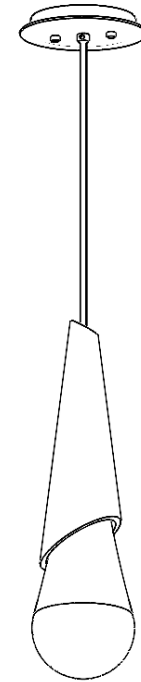

WARNING: Failure to use the LED driver to power your pendant will permanently damage your product making it unusable.

WARNING: FAILURE TO INSTALL THIS FIXTURE PROPERLY MAY RESULT IN SERIOUS PERSONAL INJURY OR DEATH AND PROPERTY DAMAGE.

It is recommended that this product be installed by a licensed electrician.

41-001-00329
Rev 2