

Included Components

- A. Hardware Packet N
 - Allen wrench
 - Pan Head Screws (2)
 - Wire Nuts (3)
- B. Blown Glass
- C. Socket Head Screw
- D. Backplate
- E. LED Driver
- F. Lightbody Assembly
- G. Universal Mounting Plate

Required Tools

1. Allen wrench (provided)
2. Philips screw driver (not provided)
3. Wire cutters/strippers (not provided)

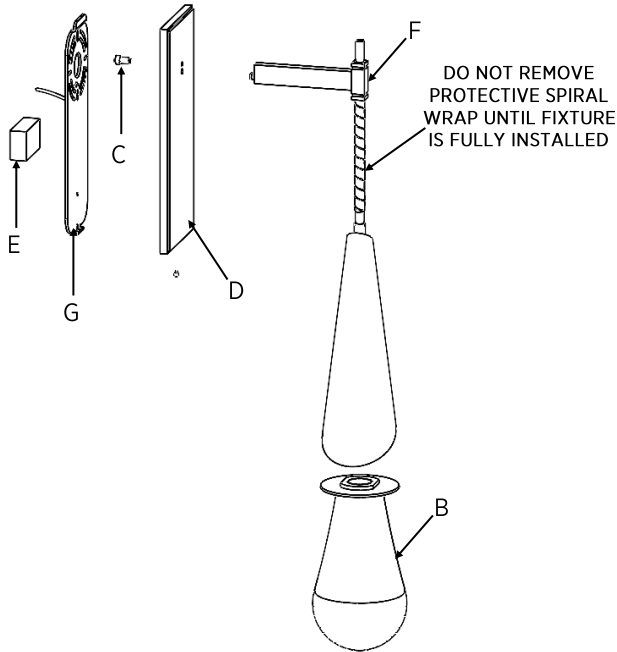

Assembly Instructions

Step 1: Install LED driver in J-Box. Dry fit driver and universal mounting plate before securing driver with double sided tape. **ENSURE SOURCE POWER IS OFF. DO NOT POWER ON UNTIL LED IS CONNECTED.**

Step 2: Make wire connections from driver to source power, **Black to Black** and **White to White**.

Note: Purple and Pink wires are only used for 0-10V dimming. Cap these wires separately if 0-10V dimming is not being used.

Step 3: Attach Universal (G) to the J-box using the provided 1.5" long #8-32 pan head screws.

Step 4: Route wires from Lightbody Assembly (F) through the larger, bottom hole in the Backplate (D). Secure the Backplate in place with the Socket Head Screw (C) using the provided Allen Wrench.

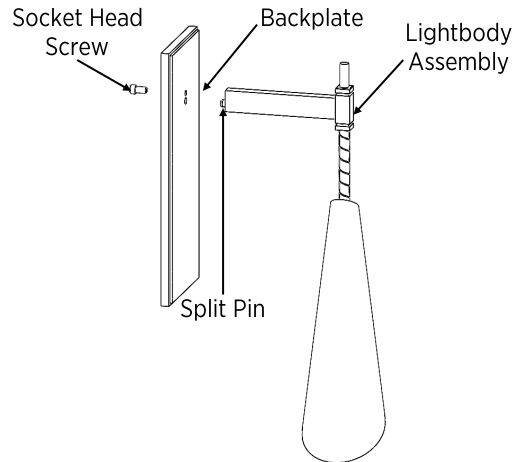

Step 5: Make wire connections to fixture. Wire connections must be made to LED driver, **Red to Red** and **Black to Blue**.

WARNING: DO NOT CONNECT FIXTURE DIRECTLY TO SOURCE POWER OR THE LED WILL BE DAMAGED.

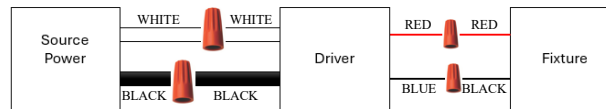

Step 6: Hang Fixture from universal and secure in place using the #8-32 set screw.

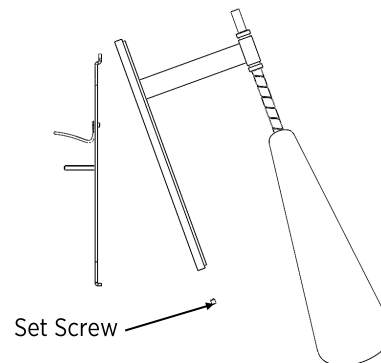

Step 7: Attach glass to sconce using the instructions below.

Raindrop Glass Install

Step 1: Place acrylic diffuser inside glass. (**Note:** diffuser may have a white protective film. Remove this prior to install)

Step 2: Raise Ceramic Cover

Step 3: Screw glass onto threaded housing

Step 4: Lower Ceramic Cover onto glass so that the foam collar folds over the glass.

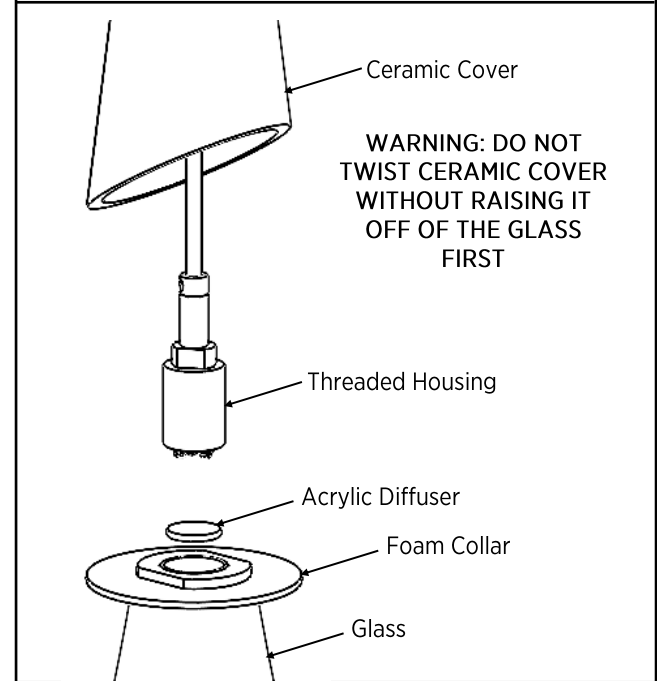

Step 8: From top to bottom, peel off the protective spiral wrap counter clockwise until it is fully removed.

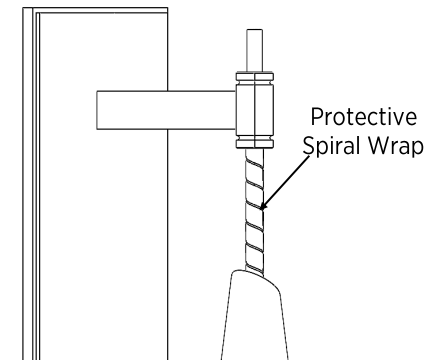

About Hammerton Studio

HAMMERTON STUDIO

When we introduced the Hammerton Studio brand in 2014, we saw an enormous opportunity to raise the bar in decorative lighting. In design, we wanted to lead rather than follow. In construction, we wanted to showcase Hammerton's renowned reverence for time-honored artisan craftsmanship and authentic materials. In performance, we wanted to provide highly reliable solutions that far exceeded industry norms for aesthetics, function, and quality. Based on the brand's dramatic growth and customer feedback, it's clear we are on the right track.

EXTRAORDINARY DESIGN VALUE IN ARTISAN GLASS & METALWORK

Hammerton began in 1995 as a blacksmith shop, but we've come a long way since then. Today we employ a world class team of metal artisans who are disciplined in a broad range of fabrication techniques and processes. We've also added in-house capabilities in blown, cast and kiln-fused glass, and today Hammerton operates one of the largest artisan glass production facilities in the U.S. With deep design and fabrication expertise at the intersection of glass and metalwork, we're laying the foundation for a new era of lighting innovation.

THE HAMMERTON HERITAGE

Our Hammerton Studio brand stands on the shoulders of more than a quarter century of experience pushing the boundaries of innovative custom lighting design. Each Hammerton Studio collection has been inspired by custom work our company has brought to life in collaboration with leading interior design professionals over the years. Built to your specifications, every fixture reflects the uncompromising design and attention to detail that is distinctly Hammerton.

A REPUTATION REFLECTED BY OUR CLIENTS

Hammerton fixtures are as extraordinary as the clients who purchase them, including Forbes 400 members, Fortune 500 leaders, award-winning entertainers, fashion and interior designers, sports legends, and leading luxury hospitality brands.

Hammerton Inc.
217 Wright Brothers Drive
Salt Lake City, UT 84116

801-973-8095
www.hammerton.com

Warranty

Please visit:
<https://studio.hammerton.com/lifetime-limited-warranty/>
to view the Hammerton Studio Warranty Policy

HAMMERTONSTUDIO™

Assembly Instructions

IDB0104-01

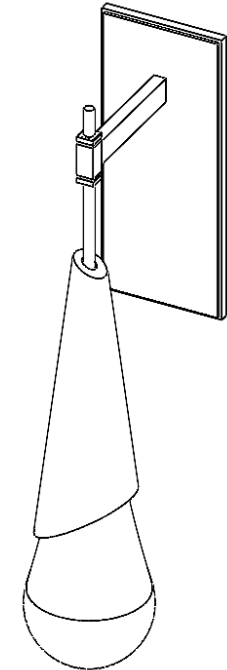

**WARNING: FAILURE TO INSTALL THIS
FIXTURE PROPERLY MAY RESULT IN
SERIOUS PERSONAL INJURY OR DEATH
AND PROPERTY DAMAGE.**

It is recommended that this product be installed
by a licensed electrician.

41-001-00330
Rev 2