

About Hammerton Studio

HAMMERTON STUDIO

When we introduced the Hammerton Studio brand in 2014, we saw an enormous opportunity to raise the bar in decorative lighting. In design, we wanted to lead rather than follow. In construction, we wanted to showcase Hammerton's renowned reverence for time-honored artisan craftsmanship and authentic materials. In performance, we wanted to provide highly reliable solutions that far exceeded industry norms for aesthetics, function, and quality. Based on the brand's dramatic growth and customer feedback, it's clear we are on the right track.

EXTRAORDINARY DESIGN VALUE IN ARTISAN GLASS & METALWORK

Hammerton began in 1995 as a blacksmith shop, but we've come a long way since then. Today we employ a world class team of metal artisans who are disciplined in a broad range of fabrication techniques and processes. We've also added in-house capabilities in blown, cast and kiln-fused glass, and today Hammerton operates one of the largest artisan glass production facilities in the U.S. With deep design and fabrication expertise at the intersection of glass and metalwork, we're laying the foundation for a new era of lighting innovation.

THE HAMMERTON HERITAGE

Our Hammerton Studio brand stands on the shoulders of more than a quarter century of experience pushing the boundaries of innovative custom lighting design. Each Hammerton Studio collection has been inspired by custom work our company has brought to life in collaboration with leading interior design professionals over the years. Built to your specifications, every fixture reflects the uncompromising design and attention to detail that is distinctly Hammerton.

A REPUTATION REFLECTED BY OUR CLIENTS

Hammerton fixtures are as extraordinary as the clients who purchase them, including Forbes 400 members, Fortune 500 leaders, award-winning entertainers, fashion and interior designers, sports legends, and leading luxury hospitality brands.

Hammerton Inc.
217 Wright Brothers Drive
Salt Lake City, UT 84116

801-973-8095
www.hammerton.com

Warranty

Please visit:
<https://studio.hammerton.com/lifetime-limited-warranty/>
to view the Hammerton Studio Warranty Policy

HAMMERTONSTUDIO™

Assembly Instructions

Iris Multi-Pendant

Image below is a representation of applicable product collection

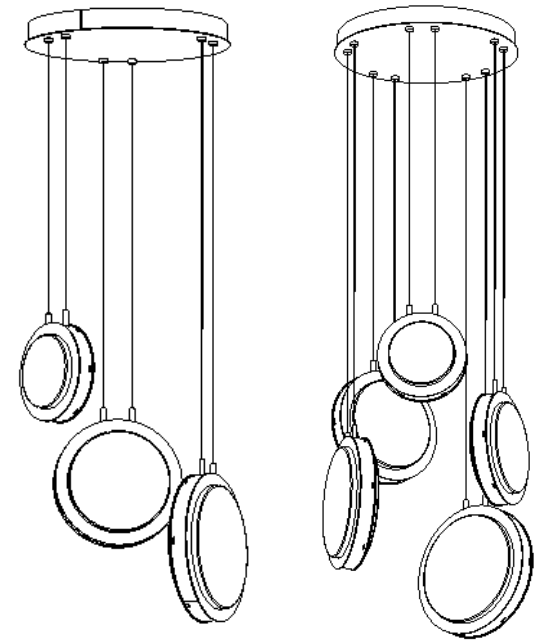

CHB0103-03/05

**WARNING: FAILURE TO INSTALL THIS
FIXTURE PROPERLY MAY RESULT IN
SERIOUS PERSONAL INJURY OR DEATH
AND PROPERTY DAMAGE.**

It is recommended that this product be installed
by a licensed electrician.

41-001-00338
Rev 1

Included Components

- A. Hardware Packet S/Z, with Instructions
- B. Canopy
- C. Canopy Face Plate
- D. Cable Stops
 - D1. Cap
 - D2. Bushing
 - D3. Bushing
- E. Cables
- F. Cable Grippers
 - F1. Cap
 - F2. Body
- G. Pendant Light Bodies
 - G1. L Iris Light Body (QTY: 2 for 5 light option)
 - G2. M Iris Light Body (QTY: 2 for 5 light option)
 - G3. S Iris Light Body

Required Tools

1. Phillips screw driver (not provided)
2. Wire cutters/strippers (not provided)
3. Measuring tape (not provided)
4. Level (not provided)
5. Diagonal Cable Cutters (not provided)

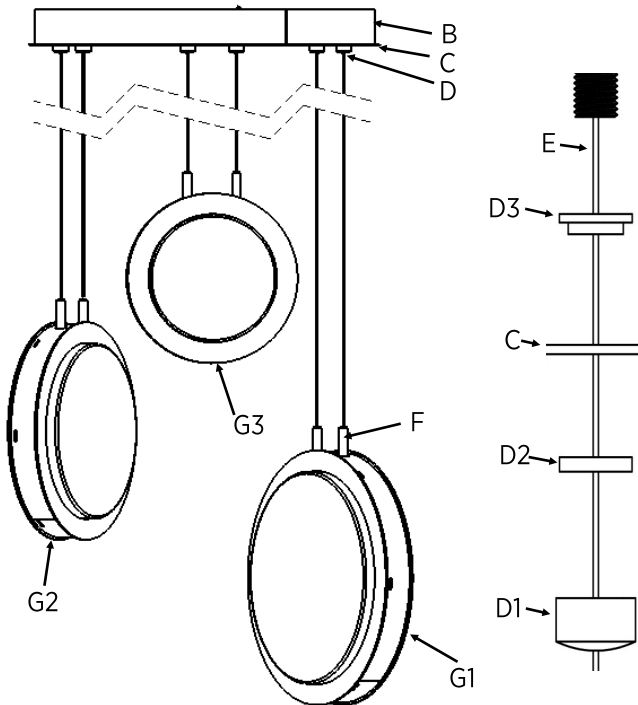

Example Fixture Shown: CHB0103-03

Warning: Source Power should be turned off. Failing to do so may result in damage to the fixture.

Assembly Instructions

Step 1: Remove Face Plate (C) From Canopy (B) by unscrewing the Cable Stop Caps (D1). The Caps (D1), Face Plate (C), and Bushings (D2, D3) will slide down cables (E).

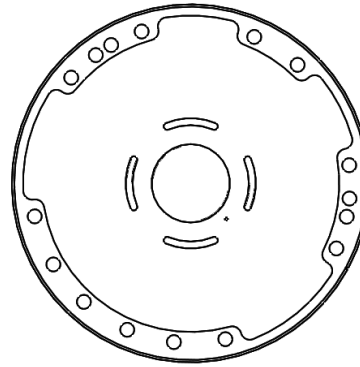

Step 2: Mount Canopy (B) to ceiling using the appropriate Hardware Packet (A) and included instructions.

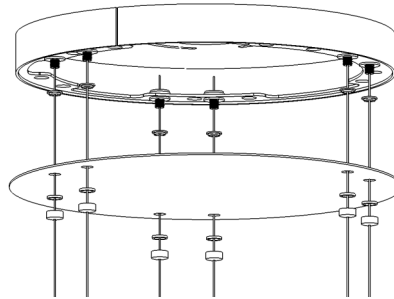

Step 3: Make wire connections to source power connecting white wire to white wire (Neutral) and Black wire to Black wire (hot) with wire nuts. Attach bare copper ground wire.

Step 4: Replace Bushings (D2, D3), Face Plate (C), and Caps (D1).

Step 5: Cables (E) and Cable Grippers (F) are marked by a numbered tag (e.g. 1-1). Each Cable (E) will be inserted into the Cable Gripper (F) marked with the same number.

Step 6: After locating the corresponding Cable (E) and Cable Gripper (F), unscrew the Cable Gripper Caps (F1). Thread the Cable (E) Caps (F1) and into the Gripper Bodies (F2).

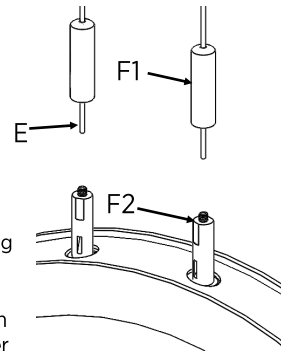

Step 7: Use a measuring tape and level to ensure the fixture is hanging at the desired distance from the Canopy. When desired height is attained cut excess Cable flush with Gripper Body. Thread Cable Gripper Cap back onto Body.

CAUTION: CABLES ARE CONDUCTIVE. DO NOT POWER FIXTURE WHILE CABLES ARE IN CONTACT WITH ANY CONDUCTIVE SURFACE. THIS INCLUDES HAVING THE CABLE PROTRUDE THROUGH THE GRIPPER AND TOUCH THE BODY OF THE LIGHT FIXTURE.

Note: Pendant light bodies can be hung at the heights you desire, but once the cable is cut you are no longer able to lower the height of the pendant. We suggest hanging all pendants then trimming the cables.

