

About Hammerton Studio

HAMMERTON STUDIO

When we introduced the Hammerton Studio brand in 2014, we saw an enormous opportunity to raise the bar in decorative lighting. In design, we wanted to lead rather than follow. In construction, we wanted to showcase Hammerton's renowned reverence for time-honored artisan craftsmanship and authentic materials. In performance, we wanted to provide highly reliable solutions that far exceeded industry norms for aesthetics, function, and quality. Based on the brand's dramatic growth and customer feedback, it's clear we are on the right track.

EXTRAORDINARY DESIGN VALUE IN ARTISAN GLASS & METALWORK

Hammerton began in 1995 as a blacksmith shop, but we've come a long way since then. Today we employ a world class team of metal artisans who are disciplined in a broad range of fabrication techniques and processes. We've also added in-house capabilities in blown, cast and kiln-fused glass, and today Hammerton operates one of the largest artisan glass production facilities in the U.S. With deep design and fabrication expertise at the intersection of glass and metalwork, we're laying the foundation for a new era of lighting innovation.

THE HAMMERTON HERITAGE

Our Hammerton Studio brand stands on the shoulders of more than a quarter century of experience pushing the boundaries of innovative custom lighting design. Each Hammerton Studio collection has been inspired by custom work our company has brought to life in collaboration with leading interior design professionals over the years. Built to your specifications, every fixture reflects the uncompromising design and attention to detail that is distinctly Hammerton.

A REPUTATION REFLECTED BY OUR CLIENTS

Hammerton fixtures are as extraordinary as the clients who purchase them, including Forbes 400 members, Fortune 500 leaders, award-winning entertainers, fashion and interior designers, sports legends, and leading luxury hospitality brands.

Hammerton Inc.
217 Wright Brothers Drive
Salt Lake City, UT 84116

801-973-8095
info@hammerton.com
www.hammerton.com

Warranty

Please visit:

<https://studio.hammerton.com/lifetime-limited-warranty>
to view the Hammerton Studio Warranty Policy

HAMMERTON STUDIO™

Assembly Instructions Iris Single Surface Mount

SMB0103-01

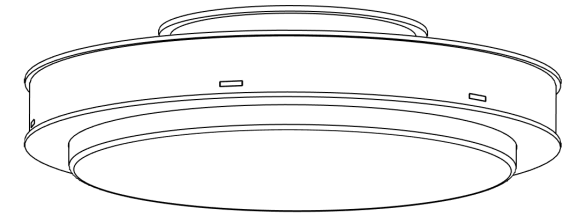

WARNING: Failure to use the LED driver to power your fixture will permanently damage your product making it unusable.

WARNING: FAILURE TO INSTALL THIS FIXTURE PROPERLY MAY RESULT IN SERIOUS PERSONAL INJURY OR DEATH AND PROPERTY DAMAGE.

It is recommended that this product be installed by a licensed electrician.

41-001-00342
Rev 2

Included Components

- A. Hardware Packet T with Instructions
- B. Canopy
- C. Driver
- D. Light Housing
- E. Glass Disc Assembly
- F. Snap-on Bezel

Required Tools

- 1. Philips screw driver (not provided)
- 2. Wire cutters/strippers (not provided)
- 3. 9/16" Wrench (not provided)

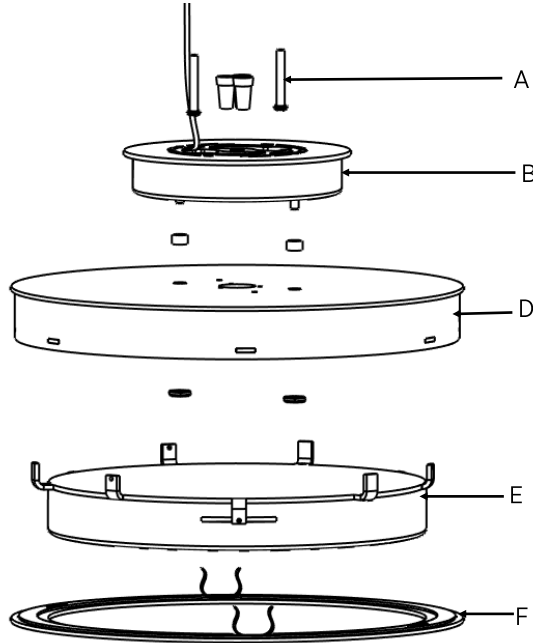

Assembly Instructions

Step 1: TURN OFF POWER TO JUNCTION BOX TO BE USED FOR INSTALLATION.

WARNING: Failure to use the LED driver to power your fixture will permanently damage your product making it unusable

Step 2: Remove light housing by unscrewing nuts, then unscrew reducers to remove the metal tin from the universal.

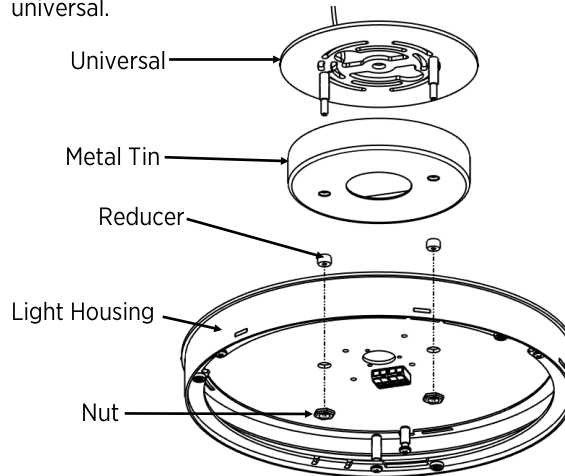

Step 3: Follow mounting packet T instructions to attach canopy universal to ceiling.

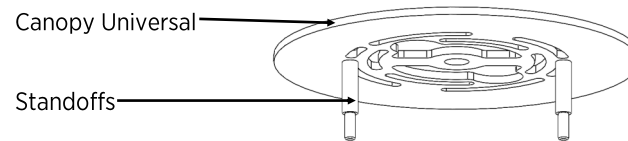

WARNING

The PURPLE and RED leads from the driver are for DC current only. If these leads or the Light Housing are connected to AC power the fixture will be damaged.

Step 4: Make wire connections from driver to source power as per mounting packet T instructions.

Step 5: Replace metal tin over all-thread, then secure with reducers, then replace light housing over reducers, and secure with nuts. **Note:** Make sure red and purple leads from canopy pass through center hole into the Light Housing.

Step 6: Connect red wire to red wire and purple wire to black wire using the appropriate Wagos.

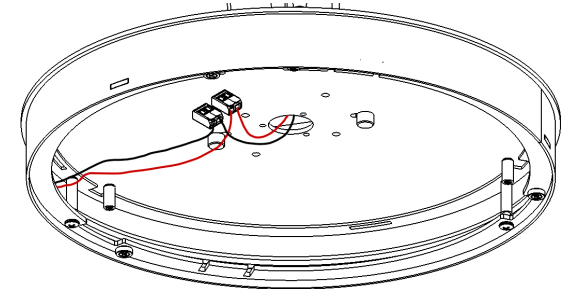

Step 7: Grip the edges of the snap-on bezel and gently pry down until the snap-on bezel pops loose. (As pictured below) Set bezel to the side.

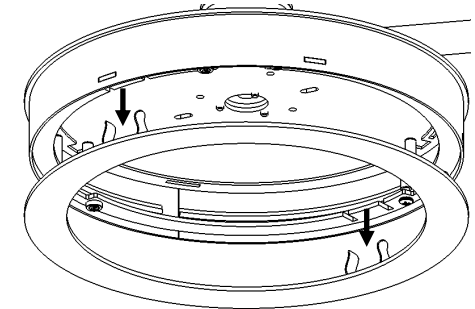

Step 8: Using 3x 5/16" 8-32 screws from hardware pack screw Glass Disc Assembly to Light Housing.

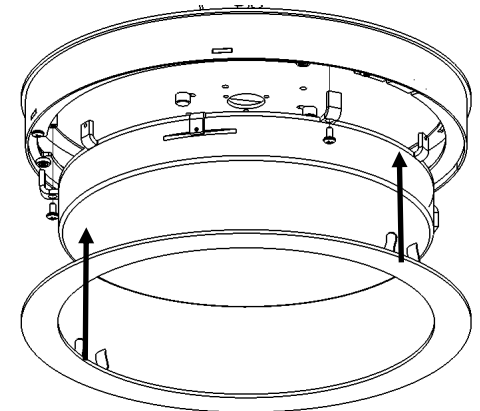

Step 9: Reinstall the snap-on bezels to the Light Housing.