

Collection: AXIS

Product #: CHB0060-35

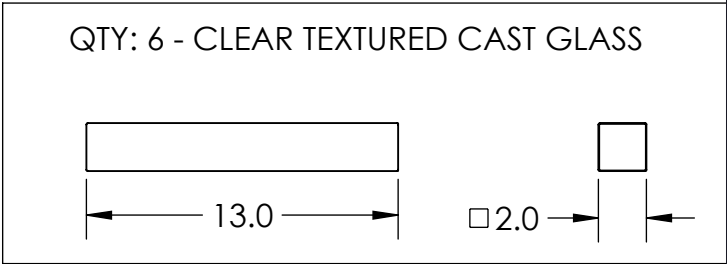
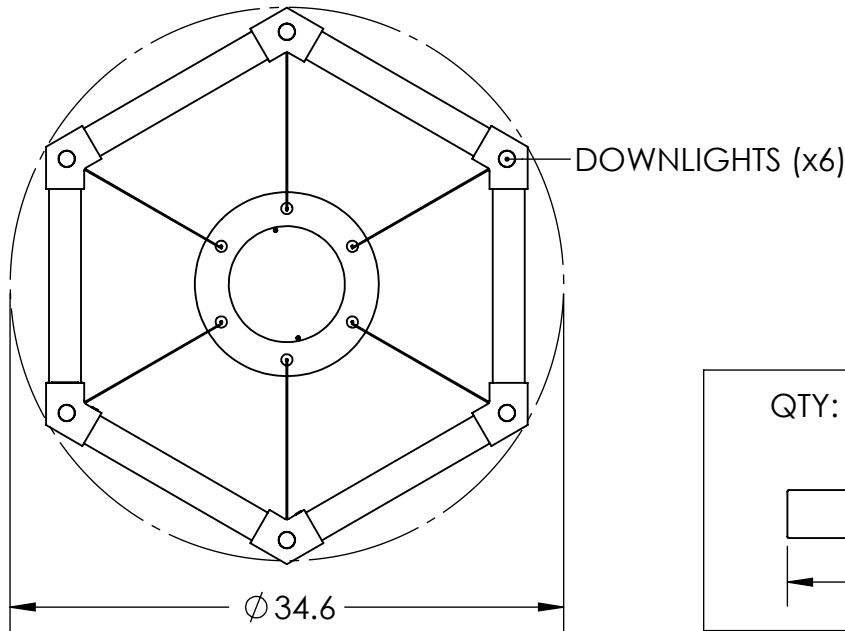
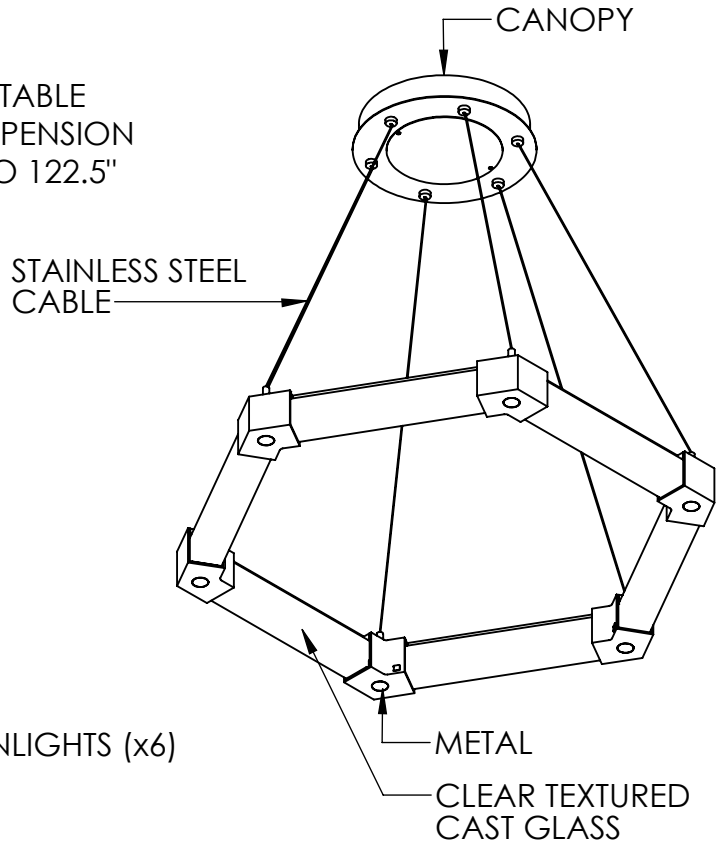
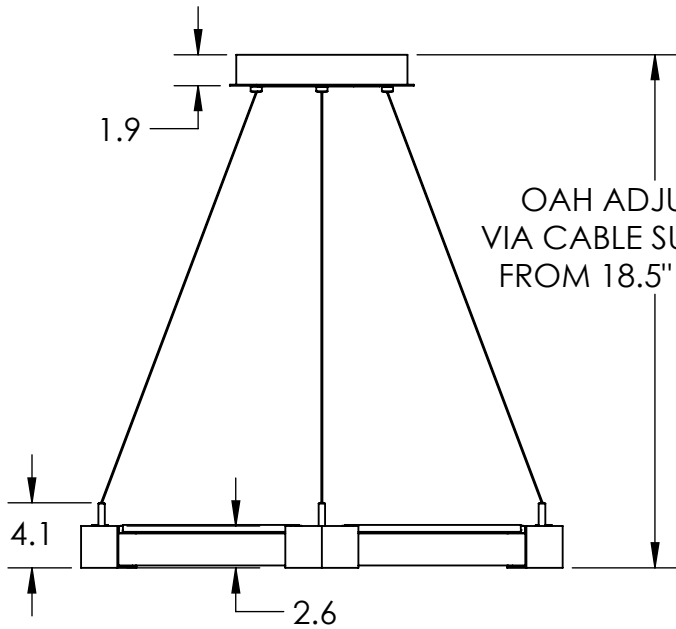

All dimensions are shown in inches unless otherwise stated.
Visit hammertonstudio.com for product options.

11/21/2025 ©

Mounting Packet: Z	Weight(lbs.): 48	Electrical Type: LED	CCT: 2700/3000 K
UL Location: DRY	Elec. Qty: 18	Wattage: 48	Voltage: 120
Finish: SEE WEB SITE FOR OPTIONS	Source Lumens: Ambient: 2160	Down: 1020	
Top Diffuser: CLOSED GLASS	Dimmable: Forward/Reverse Phase To 1%		
Bottom Diffuser: FROSTED ACRYLIC	CRI: 93+	Power Factor: >0.9	

Canopy Mounting Detail

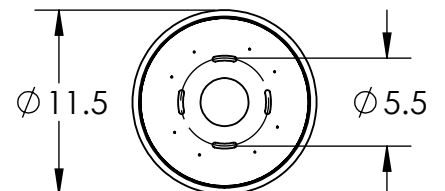

All fixtures created by Hammerton are handcrafted by artisans. Dimensions may vary up to 7/8".

© Copyright 2021. All rights in design, detail or invention of this drawing are reserved as the property of Hammerton. Any imitation or adaptation without written consent is strictly prohibited.