

Collection: Stella

Product #: CHB0070-03

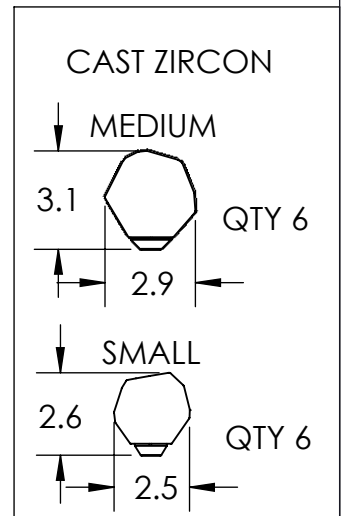
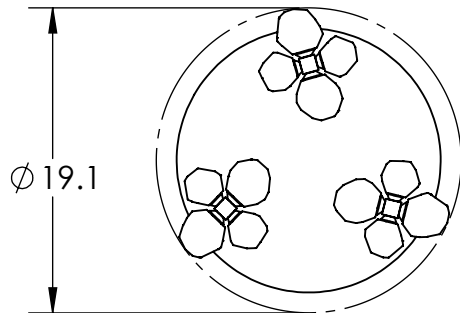
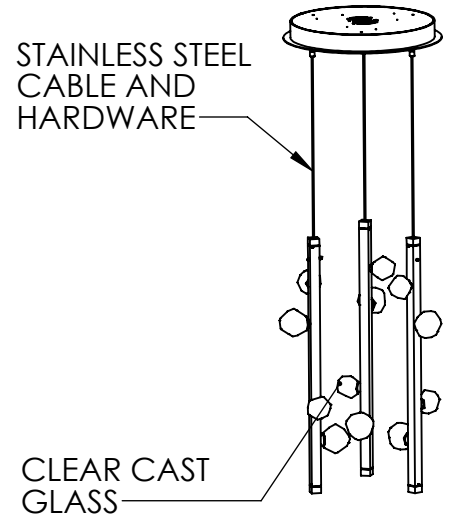
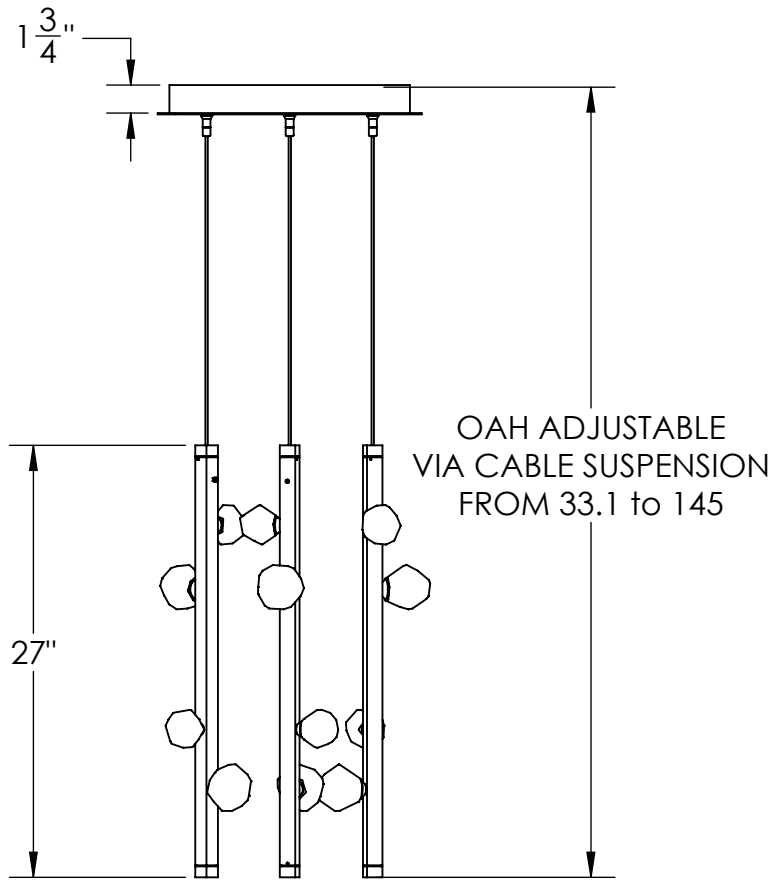

All dimensions are shown in inches unless otherwise stated.
Visit hammertonstudio.com for product options.

9/18/2023 (E)

Mounting Packet: X	Weight(lbs.): 30	Electrical Type: LED	CCT: 3000K
UL Location: DRY		Elec. Qty: 12	Wattage: 21 Voltage: 120
Finish: SEE WEBSITE FOR OPTIONS		Source Lumens: Ambient: 4106	
Top Diffuser: N/A		Dimmable: Forward/Reverse Phase To 1%	
Bottom Diffuser: N/A		CRI: 93+	Power Factor: >0.9

Canopy Mounting Detail

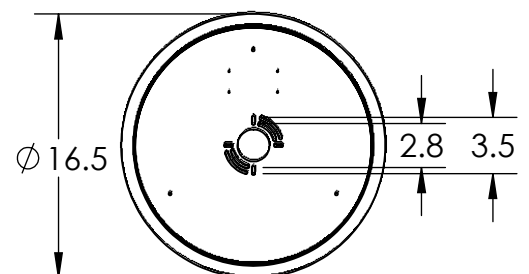

MOUNTS DIRECTLY TO J-BOX

All Hammerton fixtures are handcrafted by artisans. Subtle imperfections reflect the mark of the artisan and should be expected in any handcrafted product. Dimensions may vary up to 7/8".

© Copyright 2021. All rights in design, detail or invention of this drawing are reserved as the property of Hammerton. Any imitation or adaptation without written consent is strictly prohibited.