

All dimensions are shown in inches unless otherwise stated.

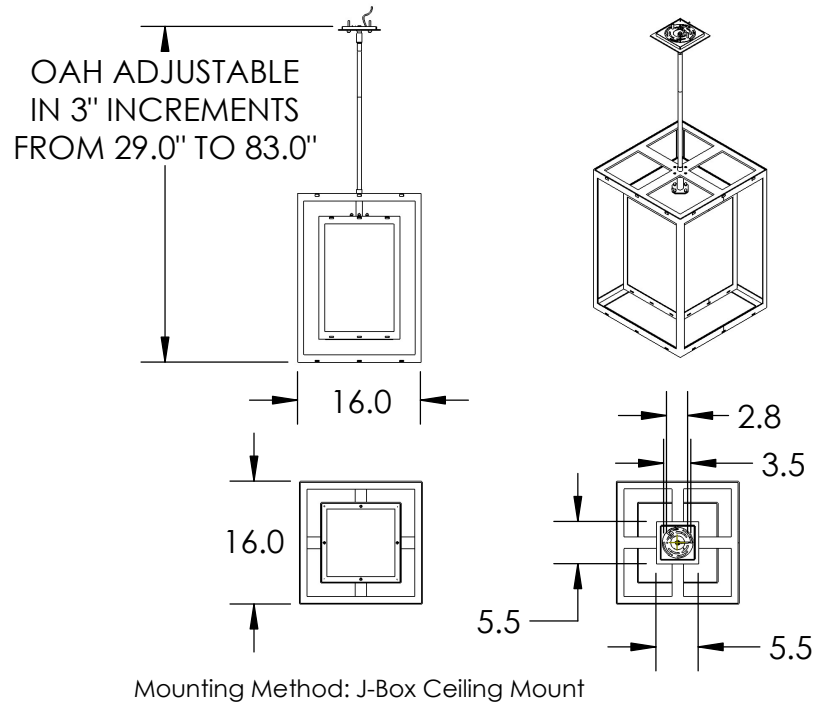

PRODUCT DESCRIPTION

This versatile contemporary pendant features a nested box design with an open outer frame and a frosted glass inner lens. AC LED lamping minimizes energy consumption and fixture maintenance.

The Double Box pendant is offered in three AAMA 2604-rated finishes that withstand UV and corrosion resistance in coastal and other harsh climates, and it includes a lifetime warranty to the original purchaser.

PRODUCT SPECIFICATION

Construction: Aluminum Body With Glass Panes

Finish Options: **AG** **SB** **TB**

Glass Types: **F**

Suspension Method: Ceiling Mount

Weight(lbs.): 24

UL Rating: Damp

Top Diffuser: Closed Metal

Bottom Diffuser: Closed Glass

Light Source: LED

Electrical Qty: 1

Wattage (Watts): 4.5

Voltage (Volts): 120

Source Lumens: 400

Dimming: ELV to 1%

CCT: 2700K or 3000K

Driver Quantity & Location: 0

CRI: 93+

Power Factor: >0.9

SCAN FOR MORE INFORMATION

Notes:

GENERAL NOTES:

Visit studio.hammerton.com to read about our Lifetime Limited Warranty.

All Hammerton fixtures are handcrafted by artisans. Subtle imperfections reflect the mark of the artisan and should be expected in any handcrafted product. Dimensions may vary up to 7/8".

Rev **E** 3/17/2026