

All dimensions are shown in inches unless otherwise stated.

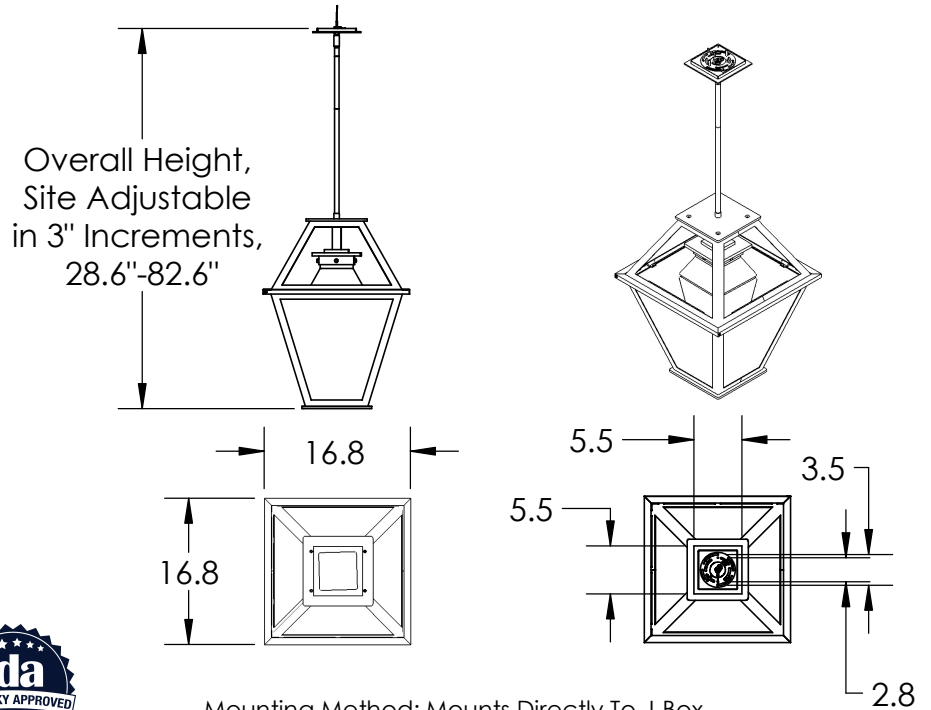

Mounting Method: Mounts Directly To J-Box

PRODUCT DESCRIPTION

A classic look that suits a broad range of transitional and traditional architectural styles, this oversized pendant design features a metal outer frame with seeded glass and an interior diffuser in hand blown glass. It is offered with a choice of incandescent and AC LED lamping, but note that **only the AC LED option is IDA Dark Sky compliant.**

The Terrace Nested Lantern Pendant is offered in three AAMA 2604-rated finishes and includes a lifetime warranty to the original purchaser.

SCAN FOR MORE INFORMATION

PRODUCT SPECIFICATION

Construction: Aluminum Body With Glass Panes and Blown Glass

Finish Options: **AG** **SB** **TB**

Glass Types: **CS**

Suspension Method: Ceiling Mount

Weight(lbs.): 25

UL Rating: Damp

Top Diffuser: Closed Metal

Bottom Diffuser: Closed Glass

Light Source: LED

Electrical Qty: 1

Wattage (Watts): 4.5

Voltage (Volts): 120

Source Lumens: 400

Dimming: ELV to 1%

CCT: 3000K

Driver Quantity & Location: 0

CRI: 93+

Power Factor: >0.9

Notes:

GENERAL NOTES:

Visit studio.hammerton.com to read about our Lifetime Limited Warranty.

All Hammerton fixtures are handcrafted by artisans. Subtle imperfections reflect the mark of the artisan and should be expected in any handcrafted product. Dimensions may vary up to 7/8".

Rev **D** 10/22/2024