

# HAMMERTON

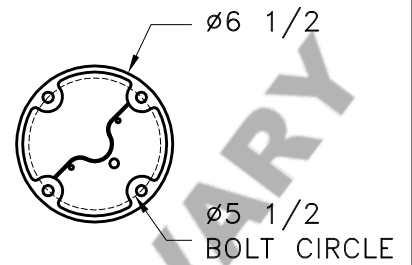

MOUNTING DETAIL

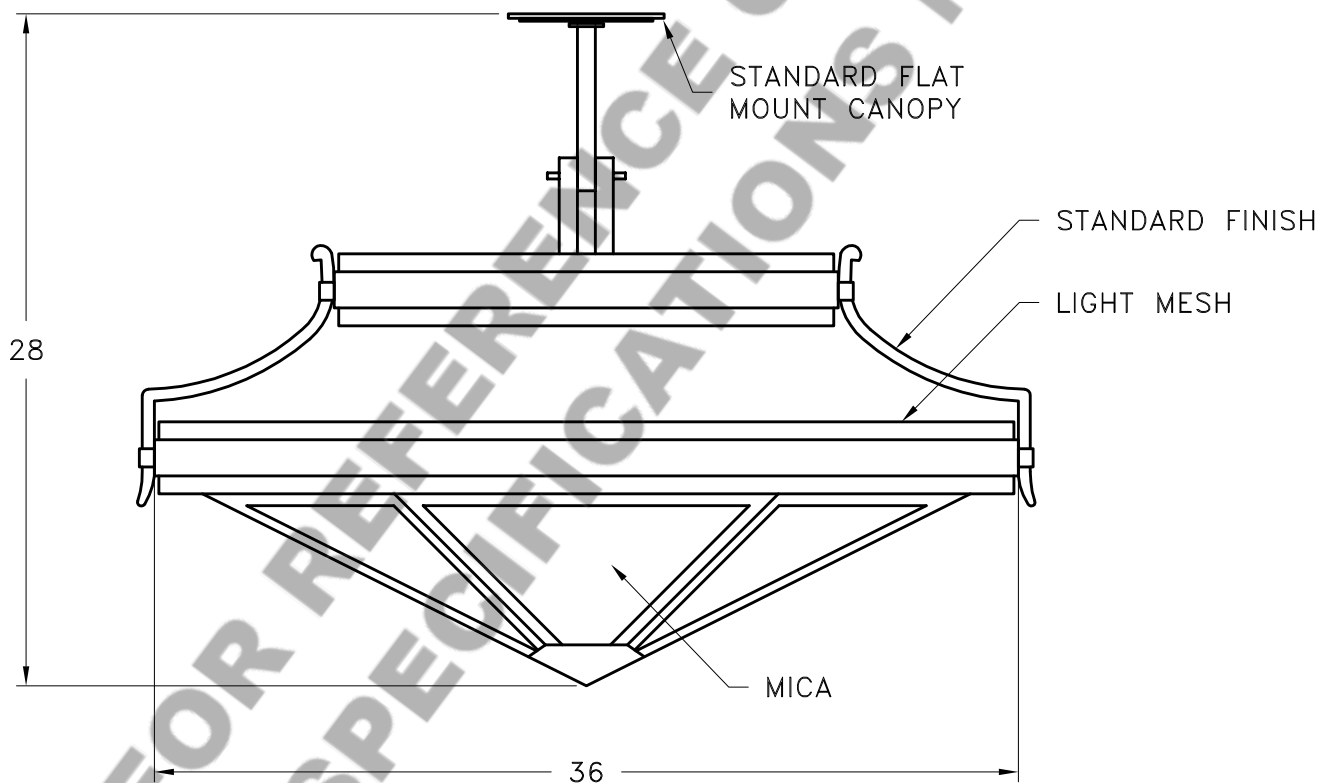

MOUNTING SPECIFICATION NOTES:

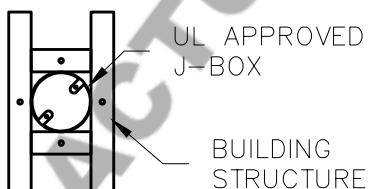

**CAUTION**  
 HARDWARE PACKET "A"  
 MOUNTS DIRECTLY TO  
 BUILDING STRUCTURE.

ELECTRICAL SPECIFICATION NOTES:

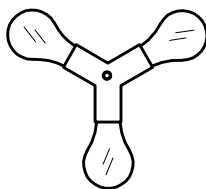

**ELECTRICAL: 3-60 WATT MAX**  
**EDISON BASE**  
**120v TYPICAL**

Light Bulb NOT Included

CATALOG # CL9209

APPROXIMATE WEIGHT: 55 Lbs.

HARDWARE PACKET: A

SHADE MATERIAL :MICA

UL RATING: DRY

DIMENSION TOLERANCE  $\pm 7/8"$ .

www.hammerton.com

© Copyright 2006, All rights in design, detail or invention of this drawing are reserved as the property of Hammerton. Any imitation or adaptation without written consent is strictly prohibited.