

# HAMMERTON

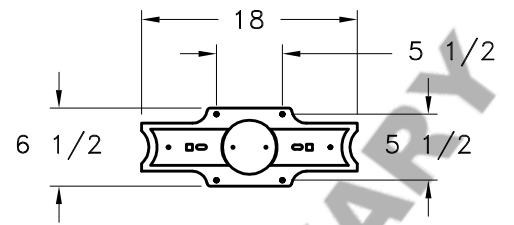

MOUNTING DETAIL  
ADDITIONAL BLOCKING REQUIRED

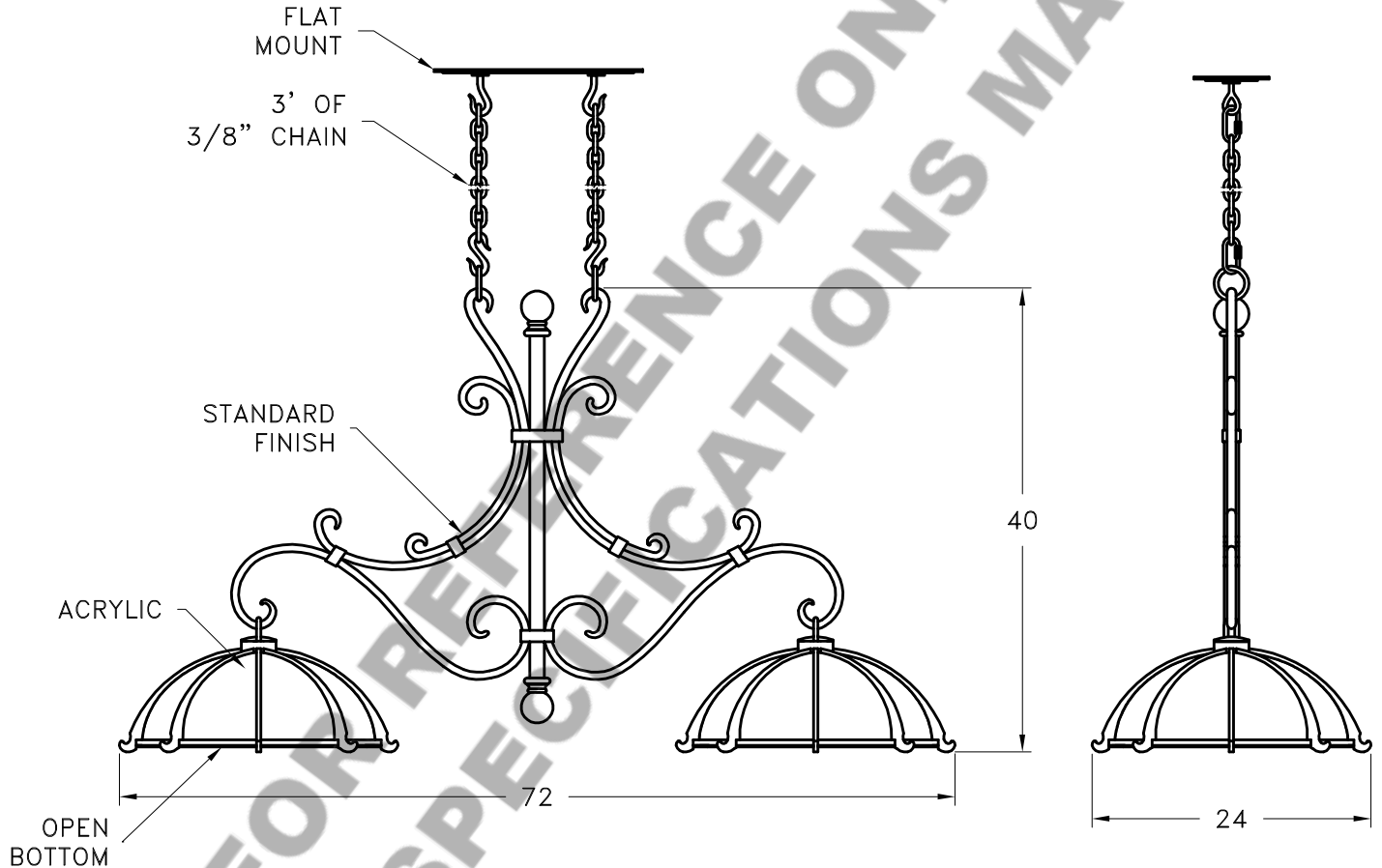

**MOUNTING SPECIFICATION NOTES:**

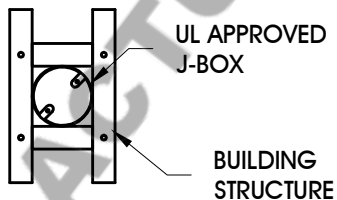

**CAUTION**  
HARDWARE PACKET "B" MOUNTS DIRECTLY TO BUILDING STRUCTURE.

**ELECTRICAL SPECIFICATION NOTES:**



**ELECTRICAL: 4-100 WATT MAX  
EDISON BASE  
120v TYPICAL**

Light Bulb NOT Included

CATALOG # PL9123

APPROXIMATE WEIGHT: 180lbs.

HARDWARE PACKET: B

SHADE MATERIAL : ACRYLIC

UL RATING: DRY

DIMENSION TOLERANCE ±7/8".

[www.hammerton.com](http://www.hammerton.com)

© Copyright 2006, All rights in design, detail or invention of this drawing are reserved as the property of Hammerton. Any imitation or adaptation without written consent is strictly prohibited.