

# HAMMERTON

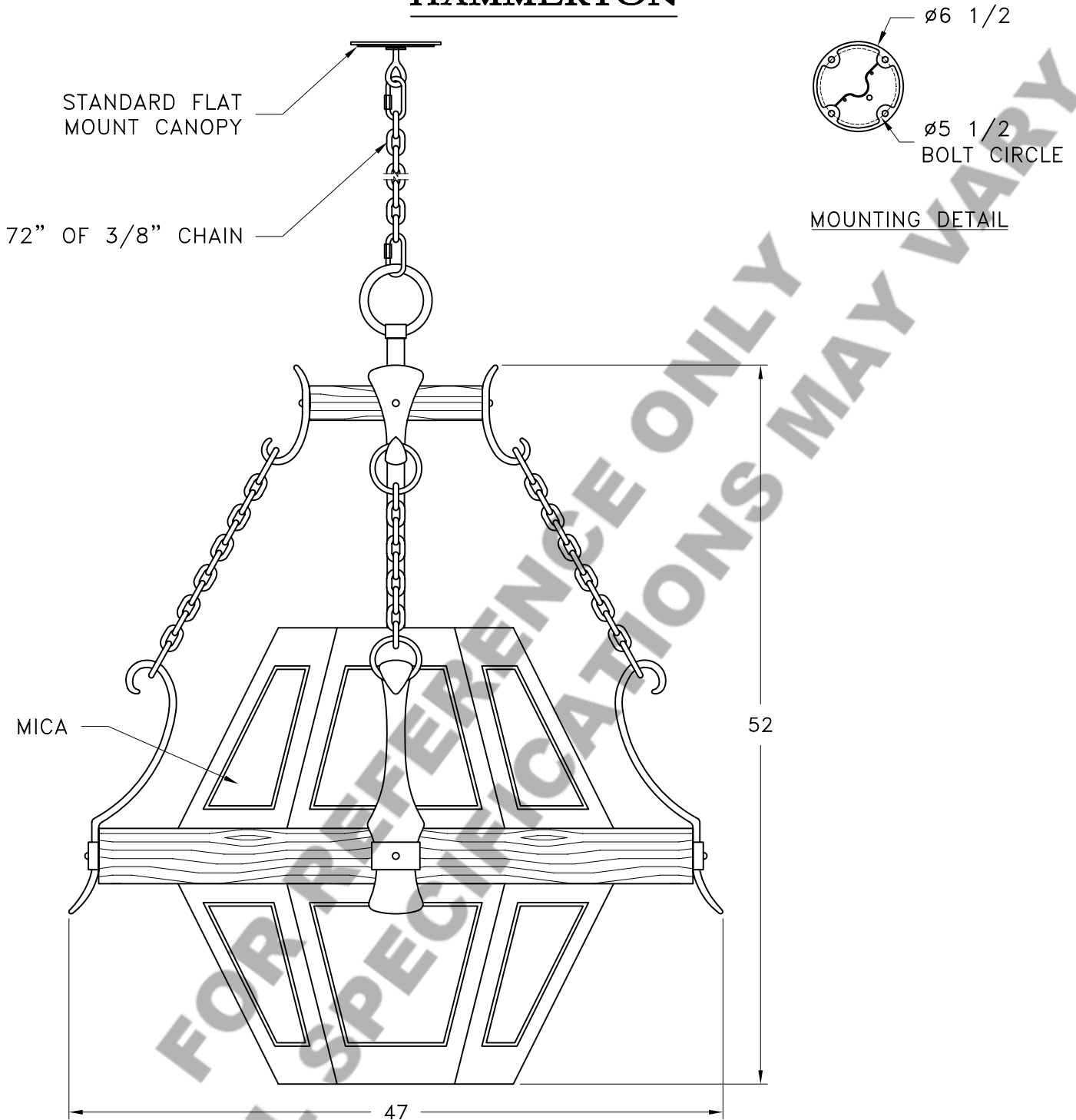

**MOUNTING SPECIFICATION NOTES:**

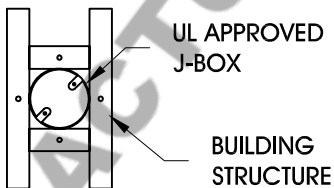

**CAUTION**

HARDWARE PACKET "A" MOUNTS DIRECTLY TO BUILDING STRUCTURE.

**ELECTRICAL SPECIFICATION NOTES:**

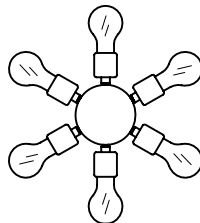

**ELECTRICAL: 6-75 WATT MAX  
EDISON BASE  
120v TYPICAL**

Light Bulb NOT Included

CATALOG # CH7159-BC

APPROXIMATE WEIGHT: 200 Lbs.

HARDWARE PACKET: A

SHADE MATERIAL : N/A

UL RATING: DRY

DIMENSION TOLERANCE ± 7/8".

[www.hammerton.com](http://www.hammerton.com)

© Copyright 2006, All rights in design, detail or invention of this drawing are reserved as the property of Hammerton. Any imitation or adaptation without written consent is strictly prohibited.