

Approved By:

Product #: CHA2170

Date:10/05/2017

**NOTE:**  
ALL METAL COMPONENTS ARE ALUMINUM

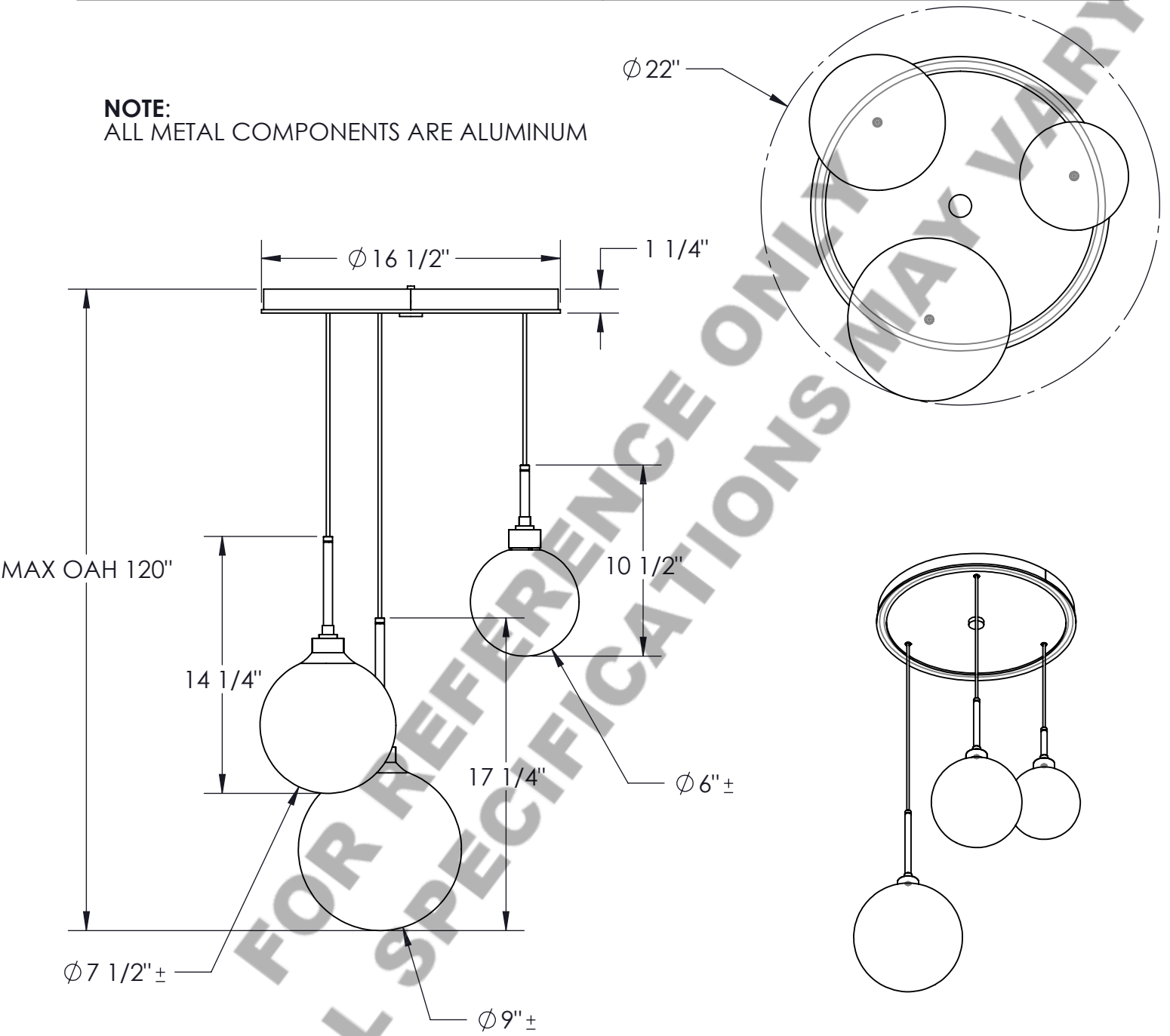

Mounting Style: FLAT	Electrical Type: LED
Approximate lbs.: 30	Bulb Qty: 3    Wattage: 16
Finish:SEE WEBSITE	Voltage:120
Top Diffuser: CLOSED METAL	Socket Type:NA
Bottom Diffuser: CLOSED GLASS	UL Location: DRY

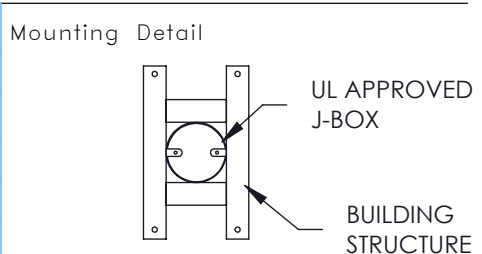

**CAUTION**  
HARDWARE PACKET "B"  
MOUNTS DIRECTLY TO BUILDING  
STRUCTURE.

All fixtures created by Hammerton are handcrafted by artisans—dimensions may vary.

© Copyright 2015. All rights in design, detail or invention of this drawing are reserved as the property of Hammerton. Any imitation or adaptation without written consent is strictly prohibited.

Hammerton Inc. 217 Wright Brothers Dr. Salt Lake City, UT 84146 (801) 973-8095